

Finite Automata

Finite Automaton

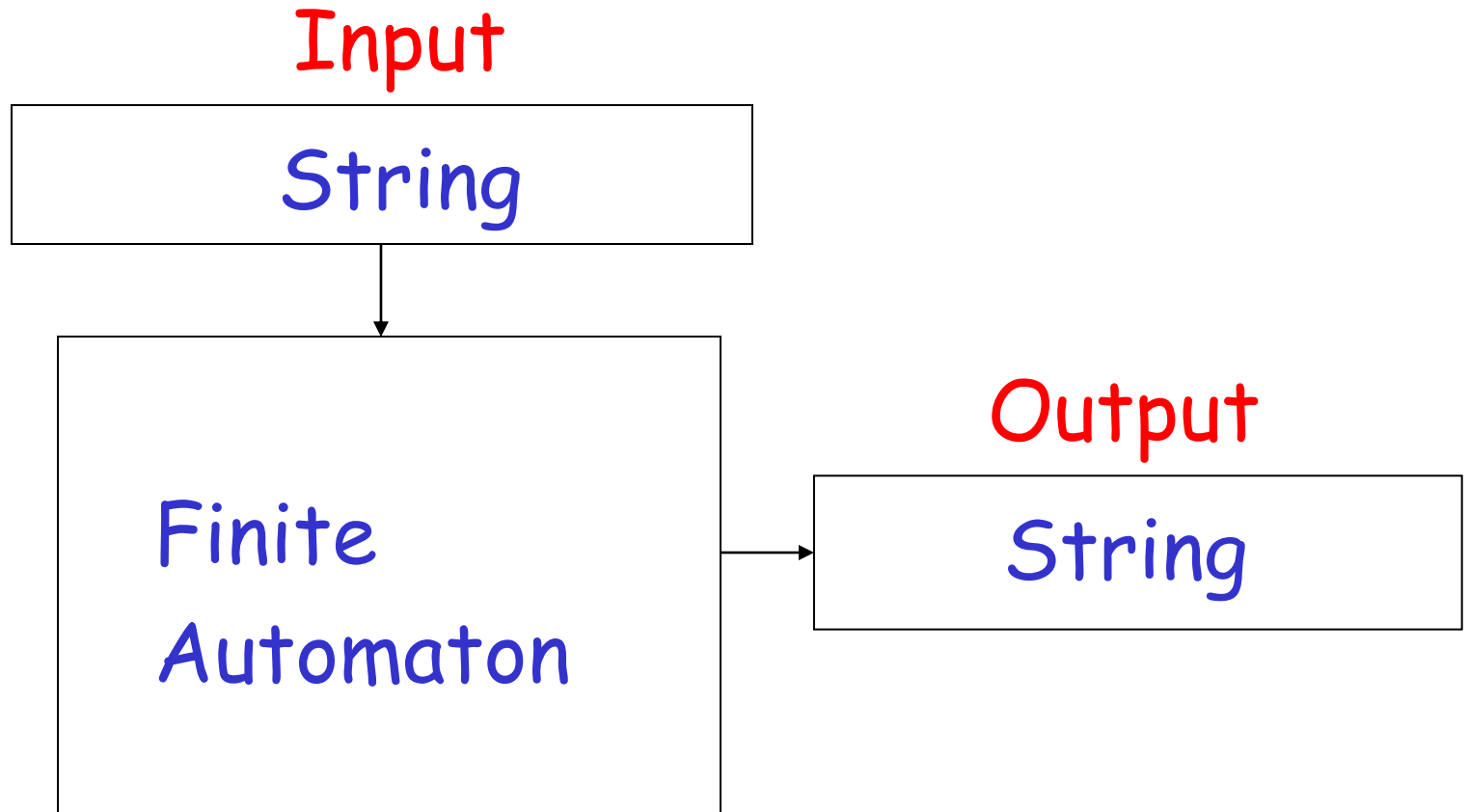

Finite Acceptor

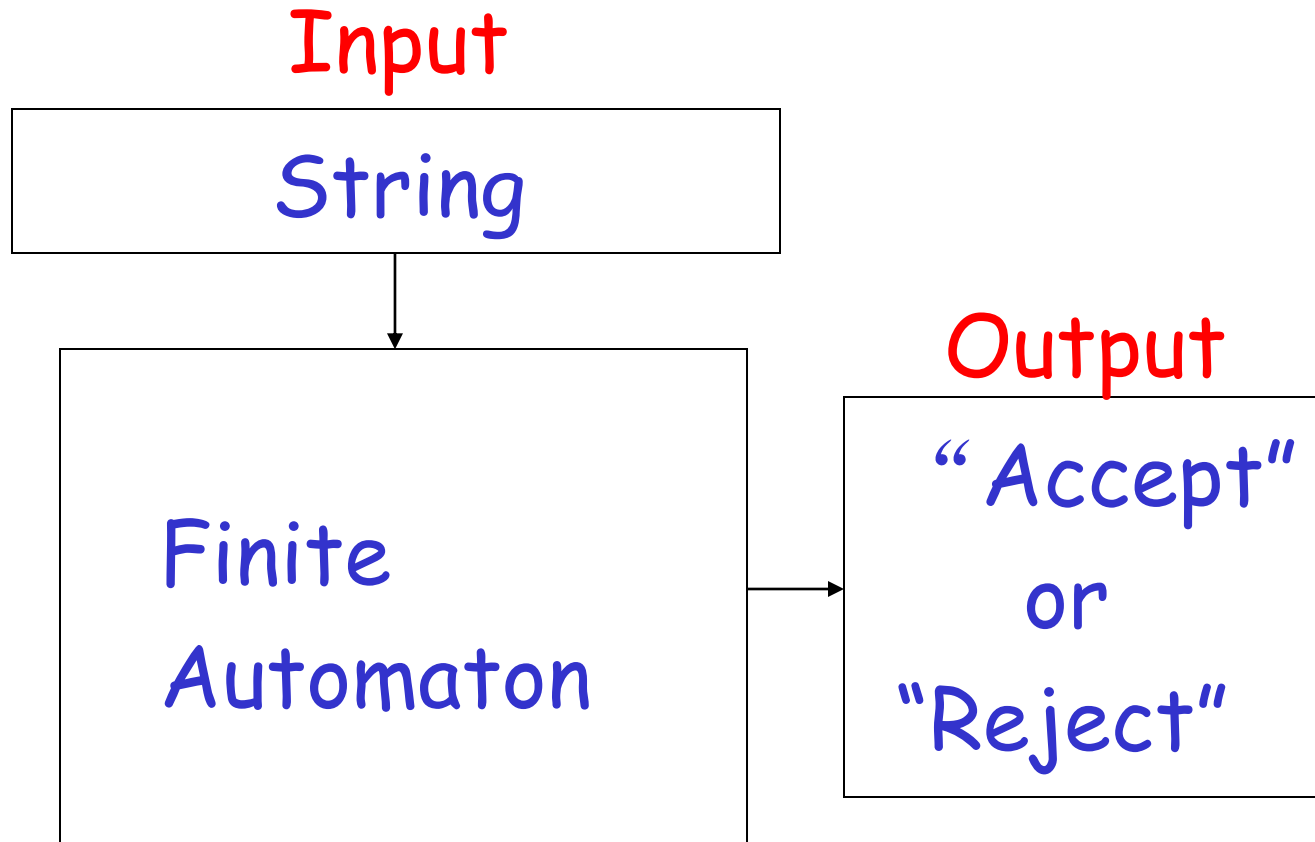

Transition Graph

Abba - Finite Acceptor

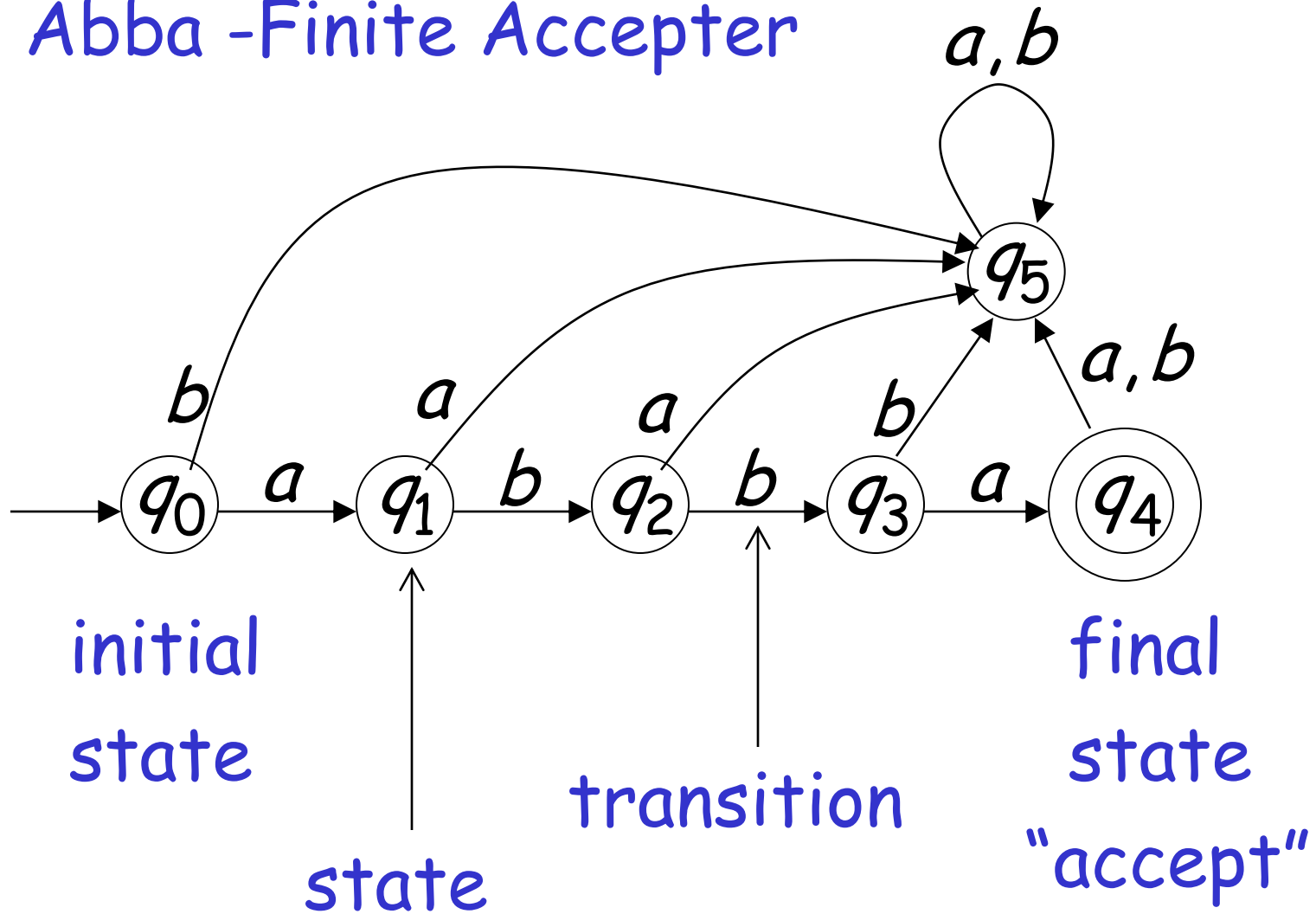

Initial Configuration

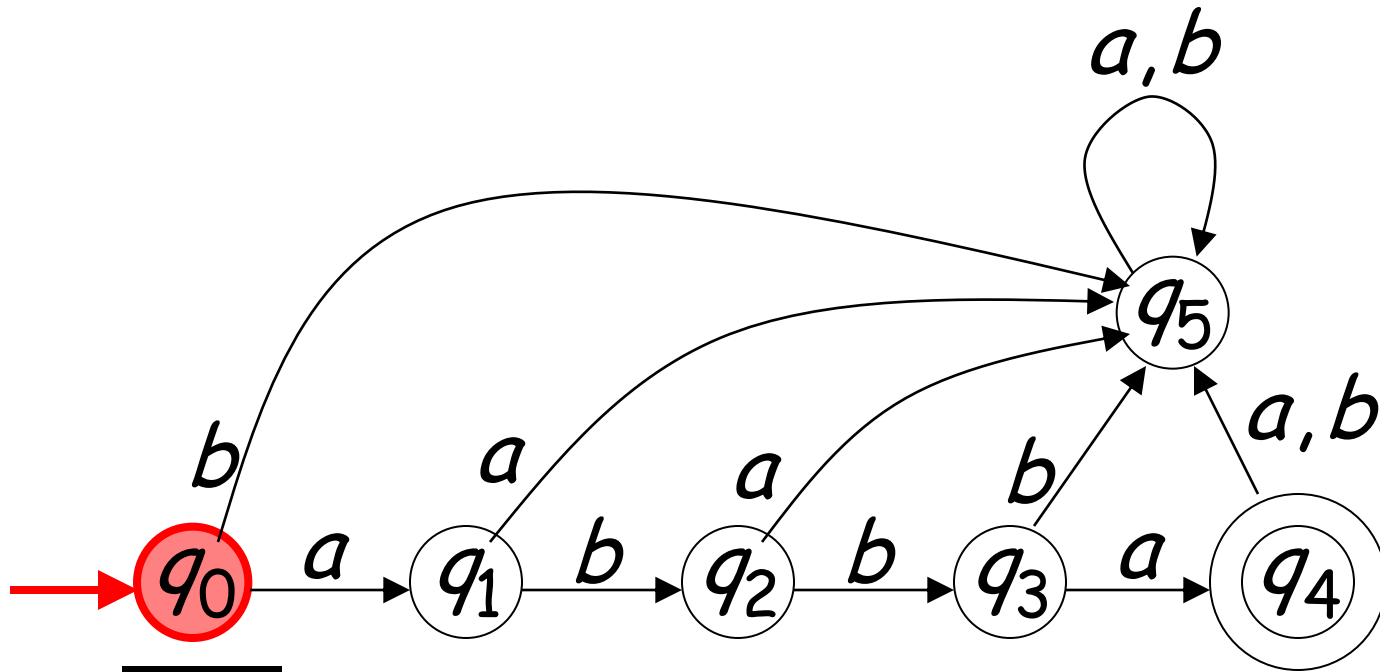

Reading the Input

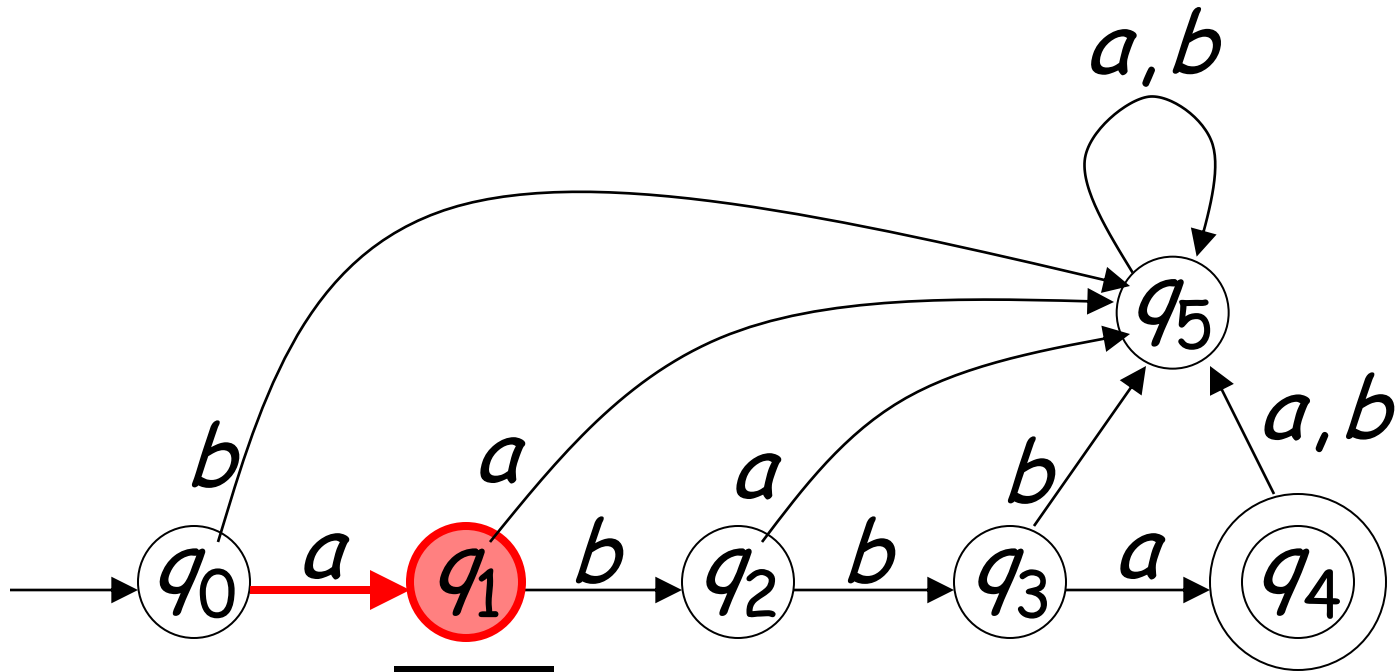
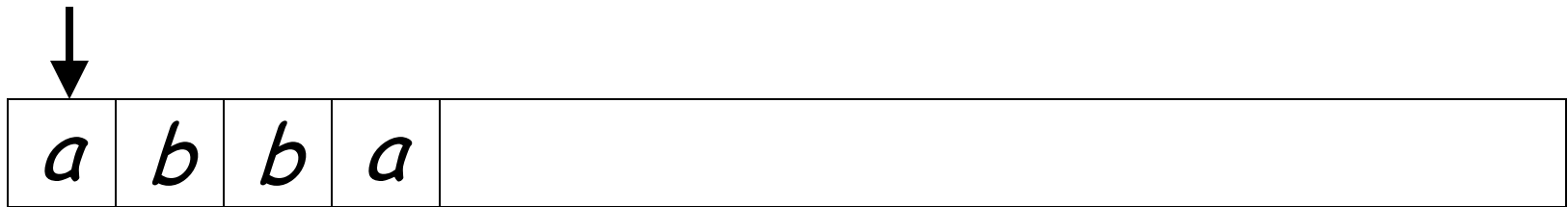

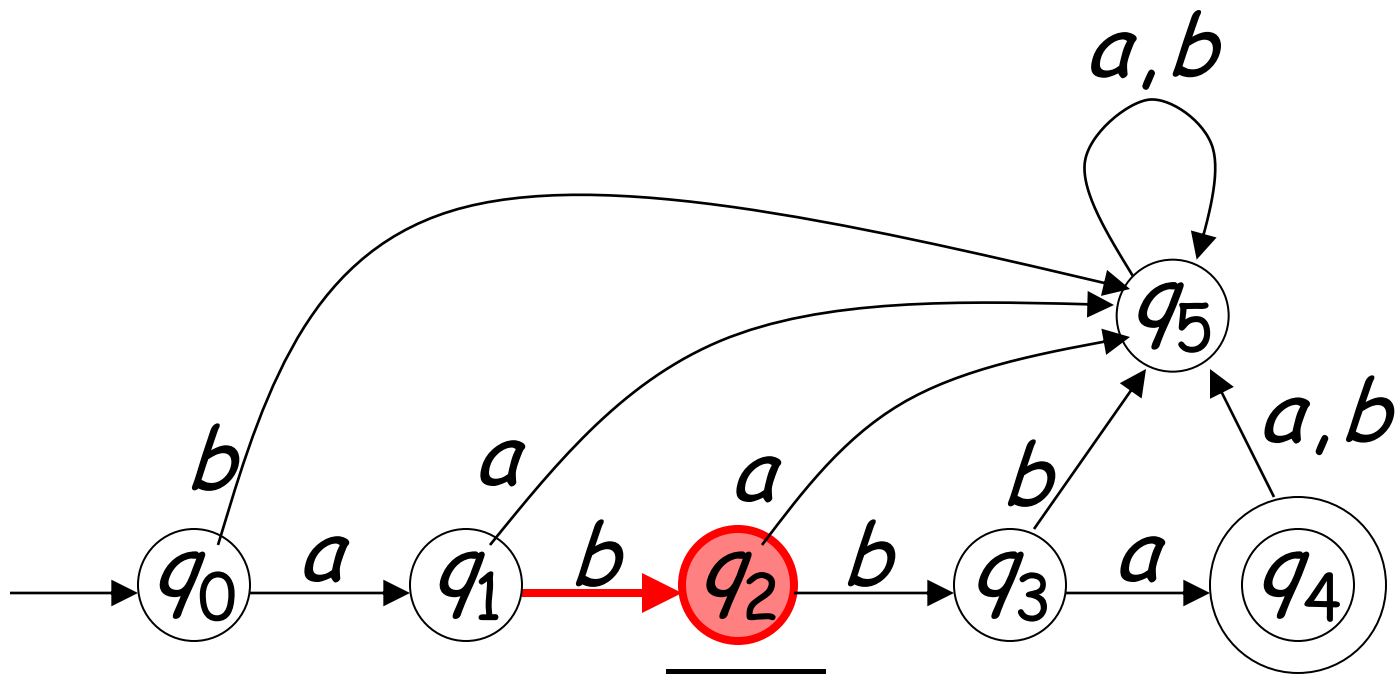
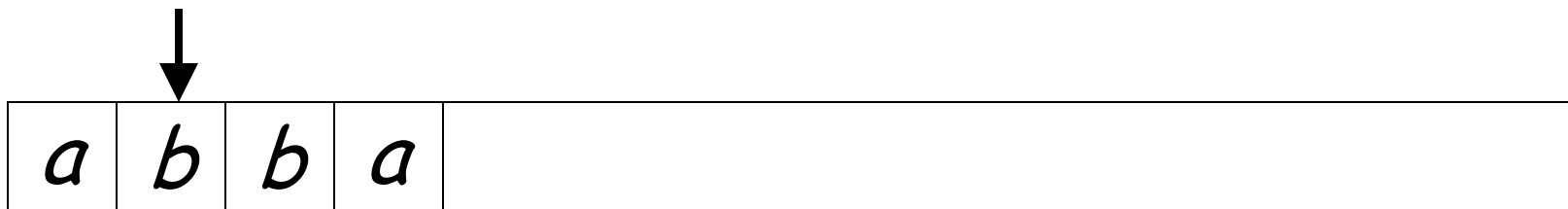

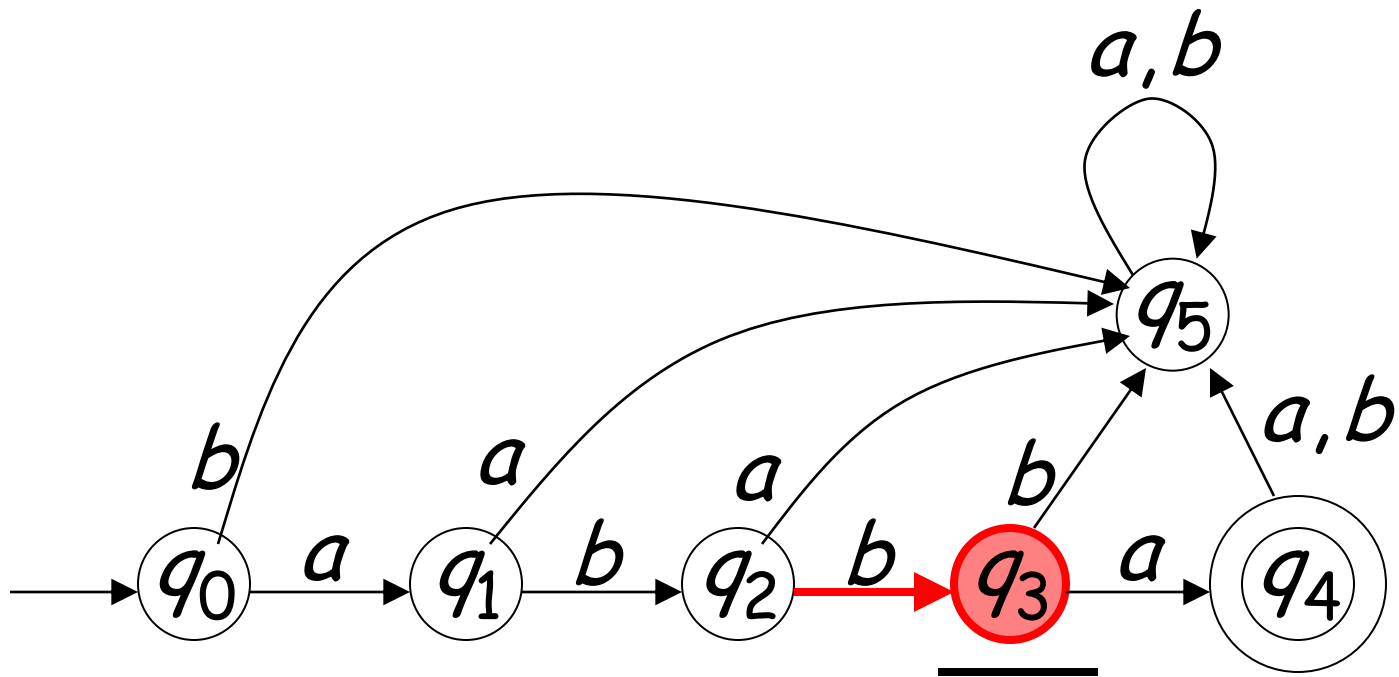
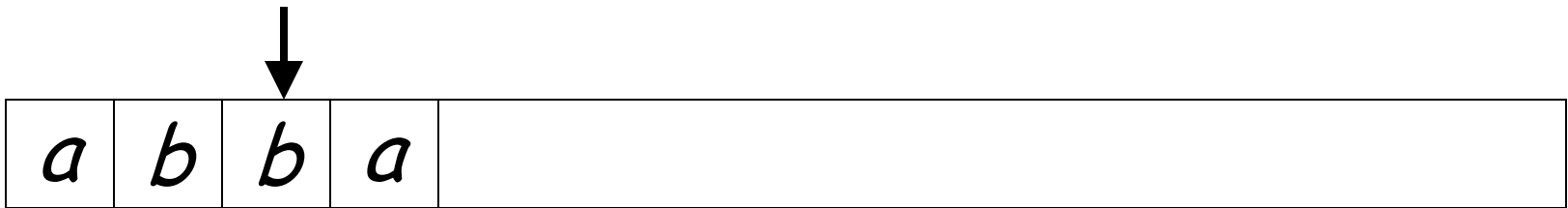

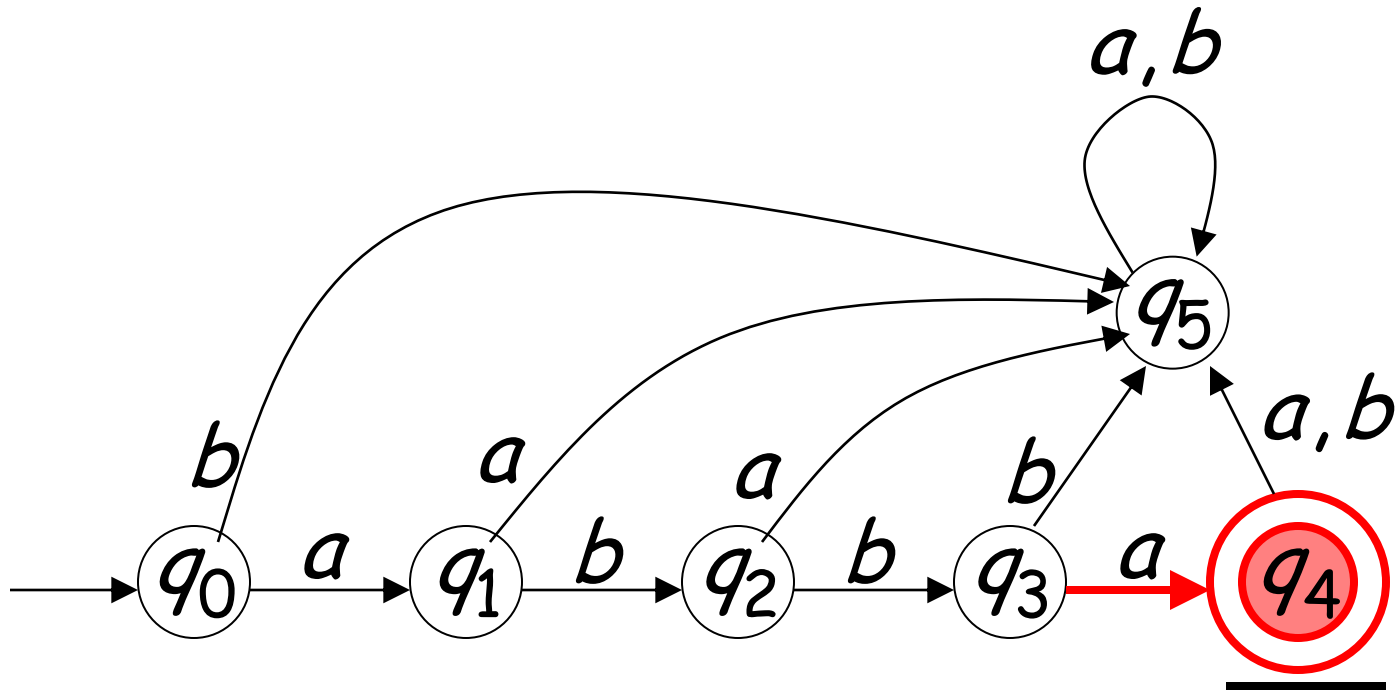
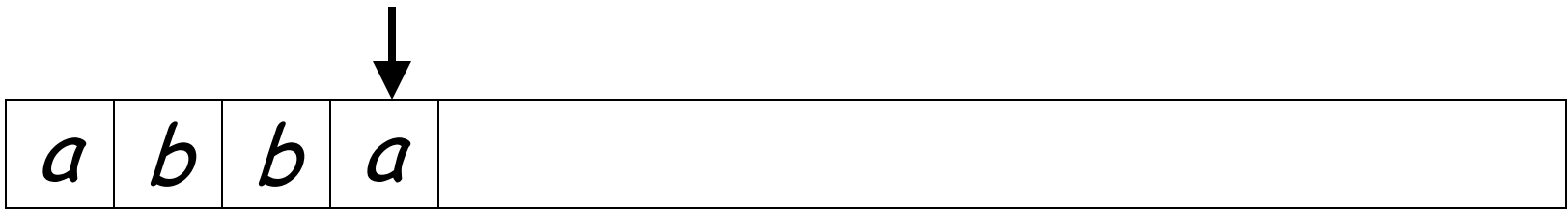

Input finished

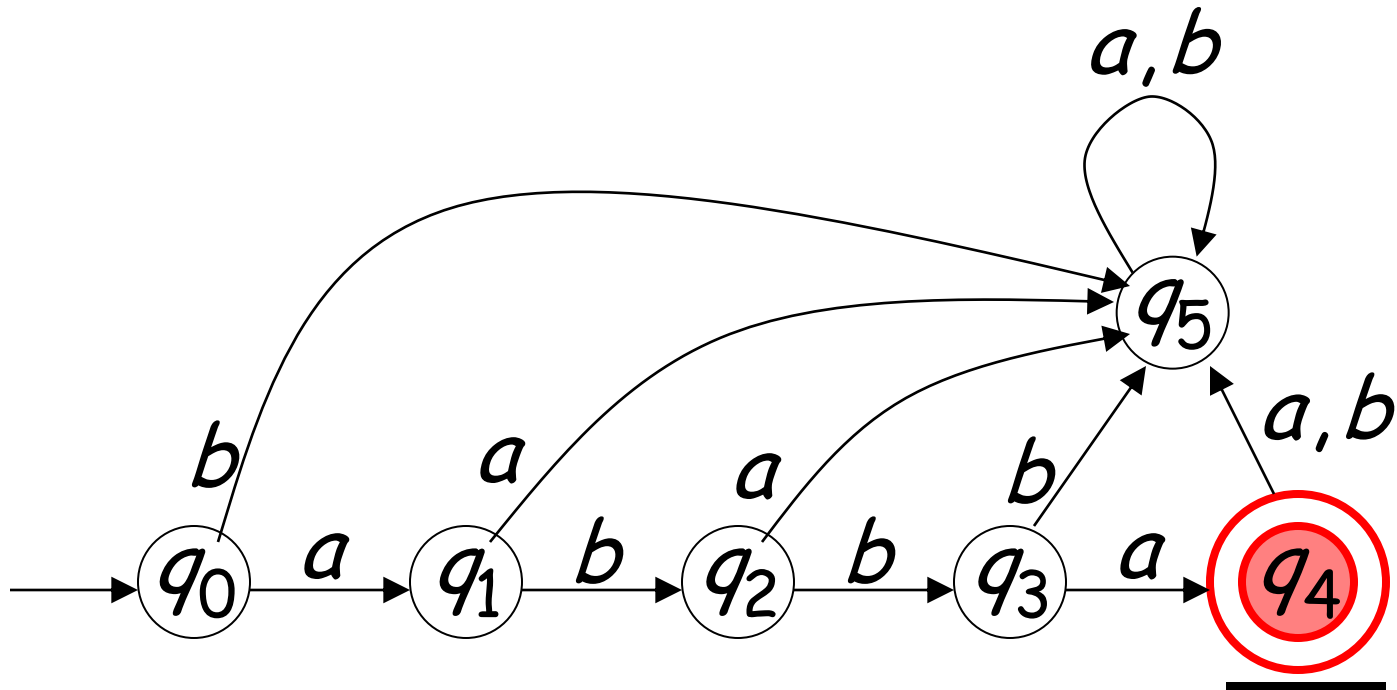
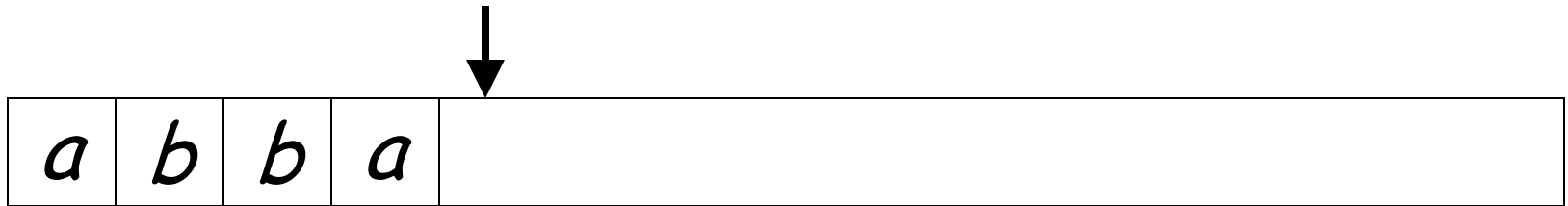

Output: "accept"

Rejection

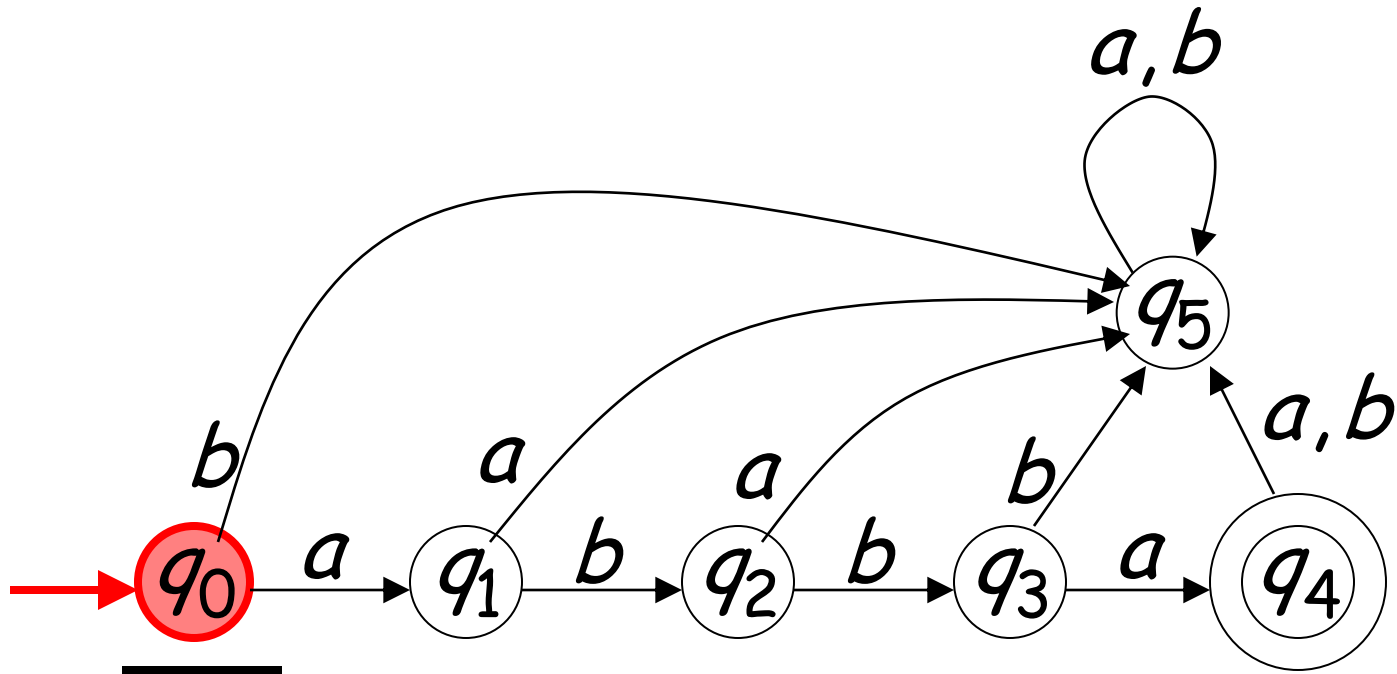
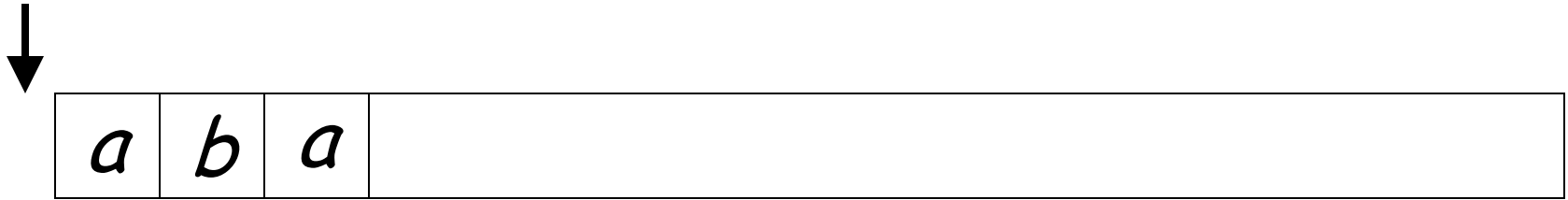

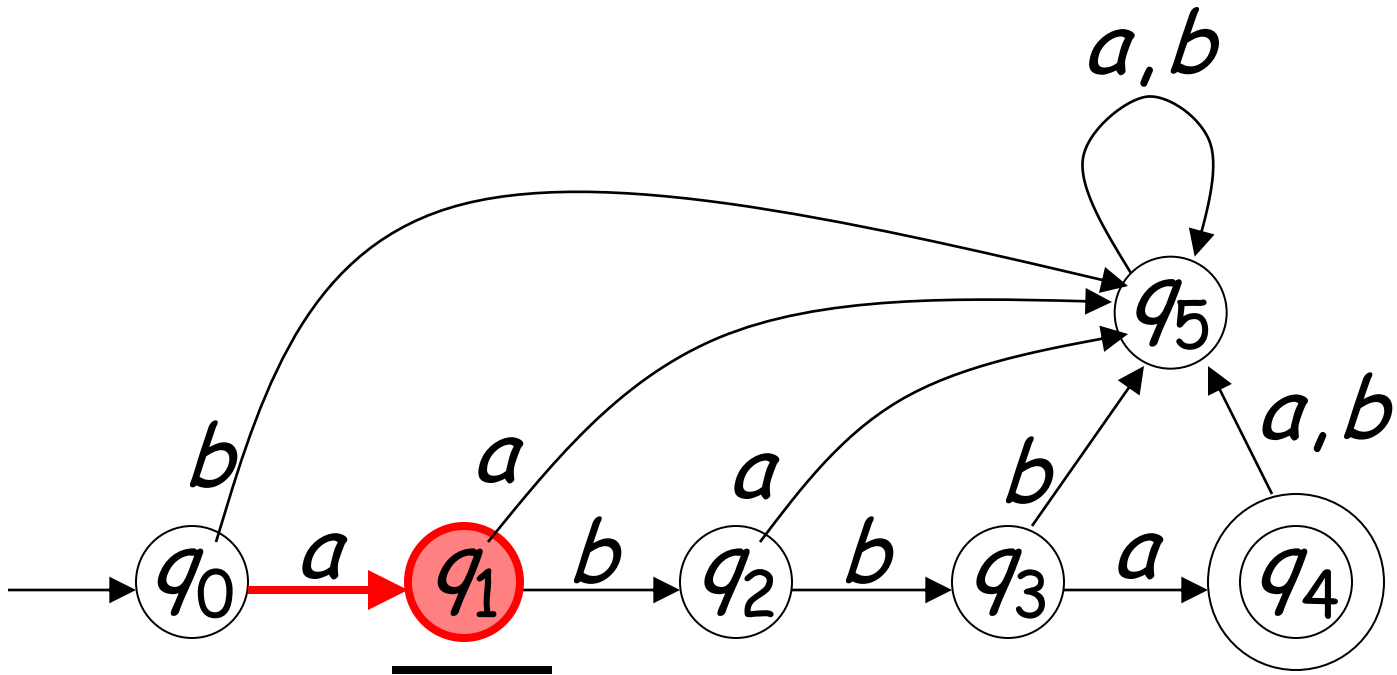
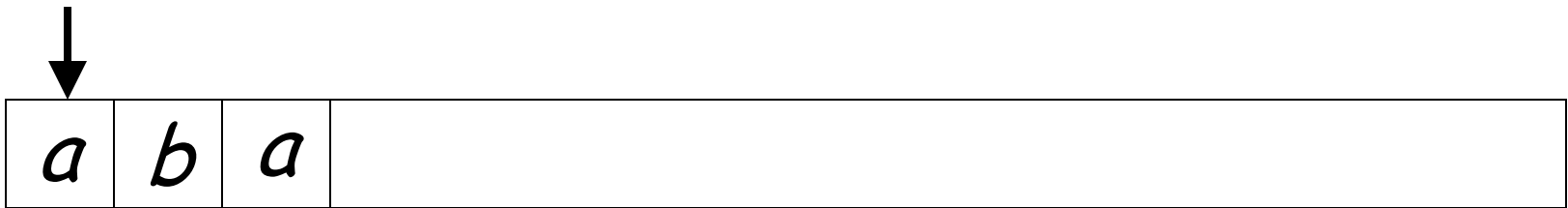

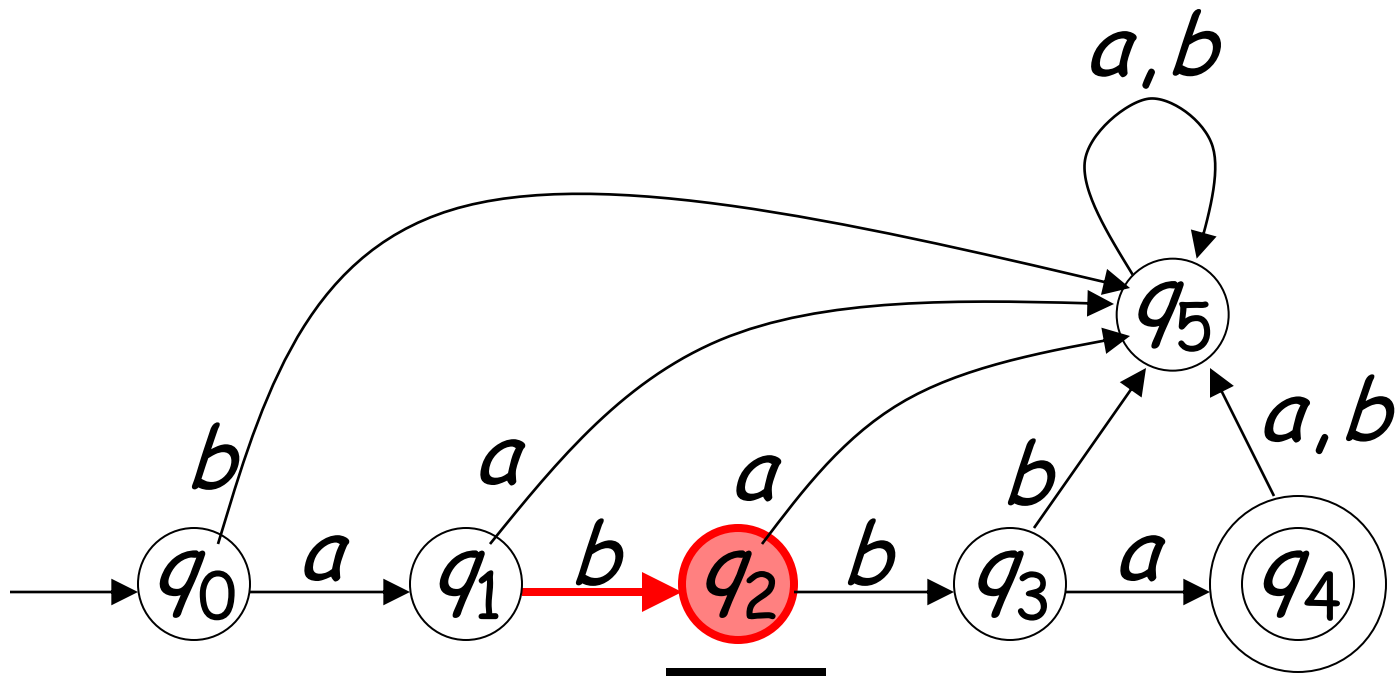
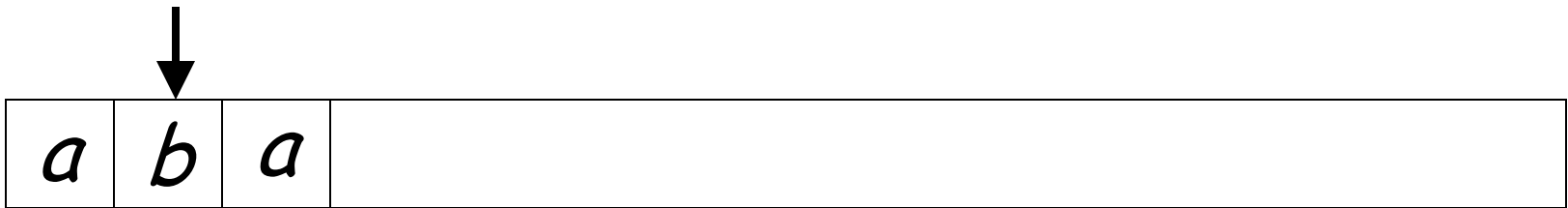

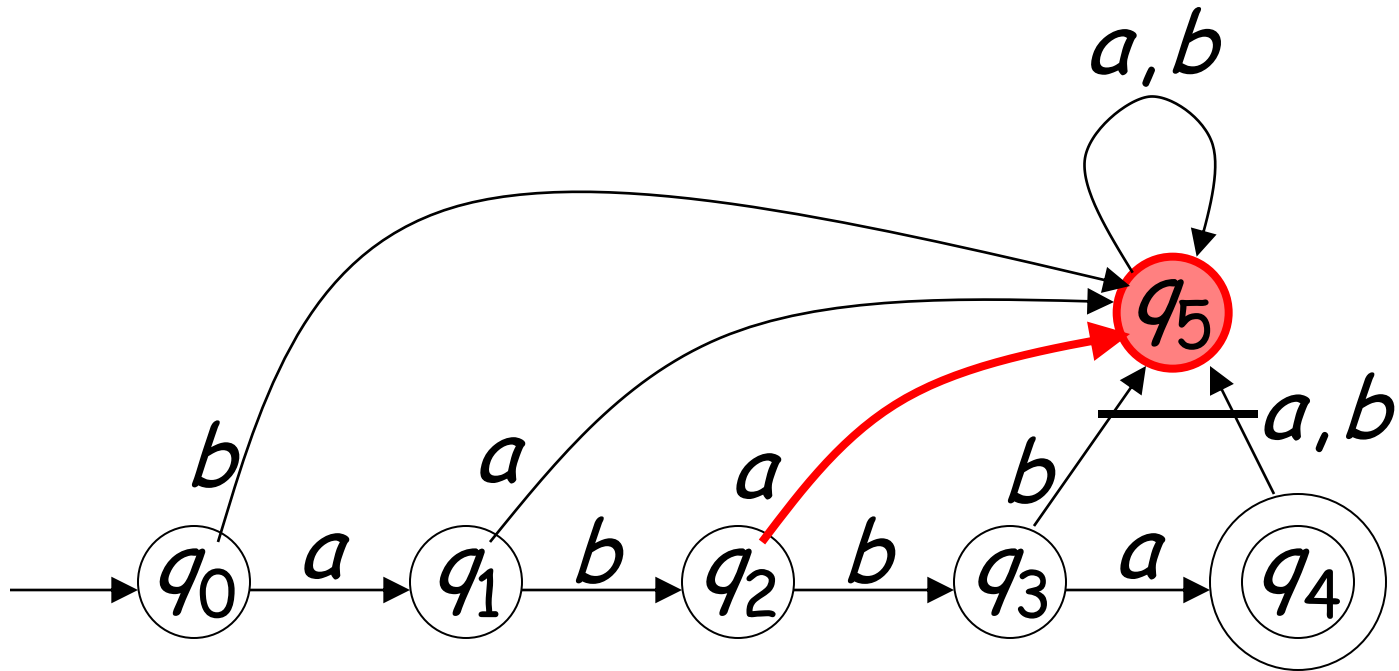
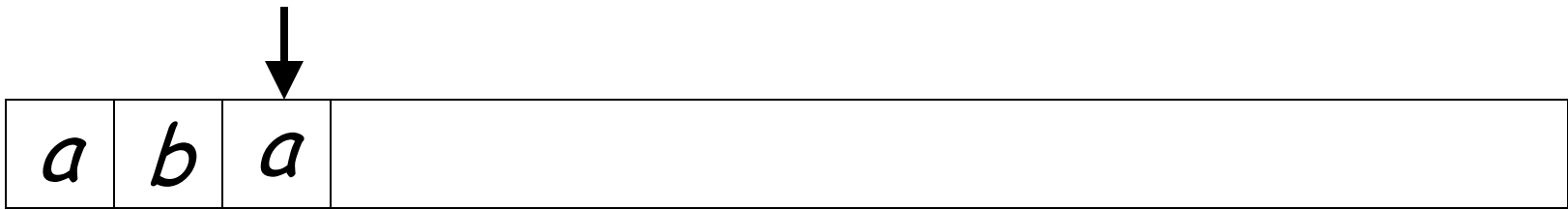

Input finished

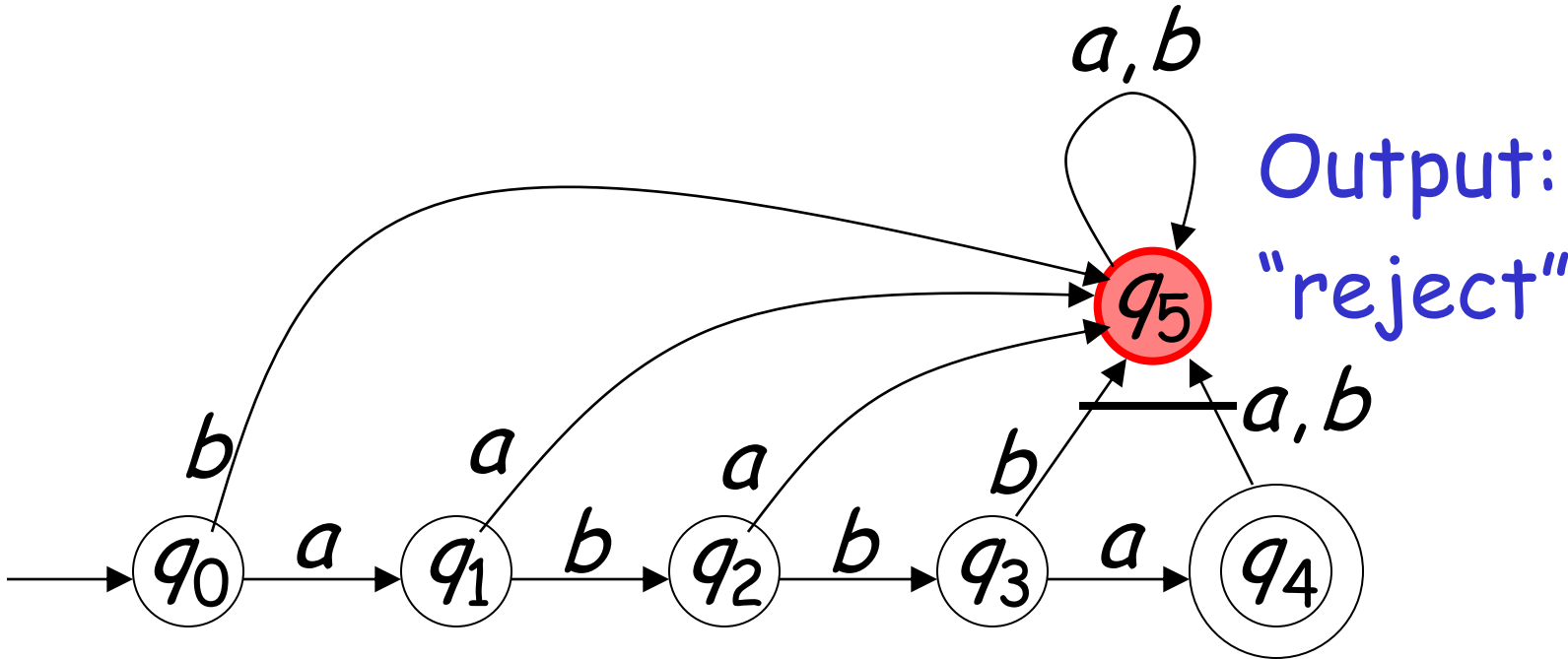

Another Rejection

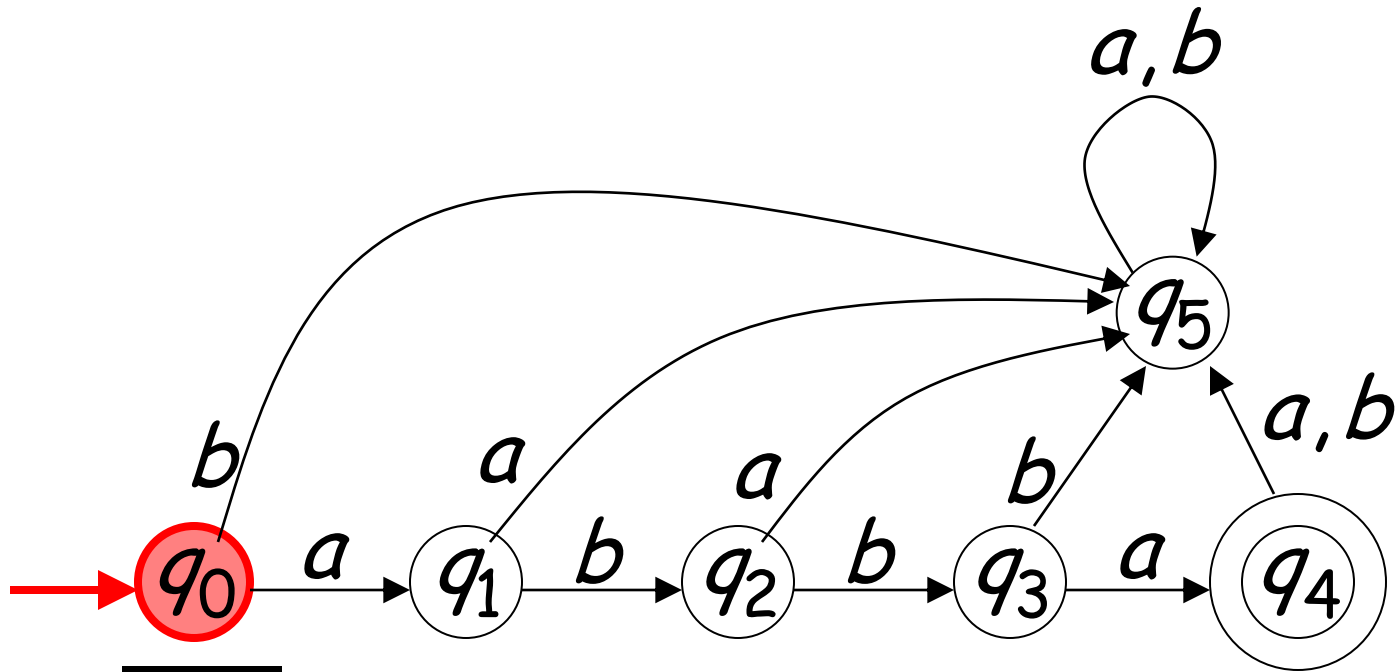
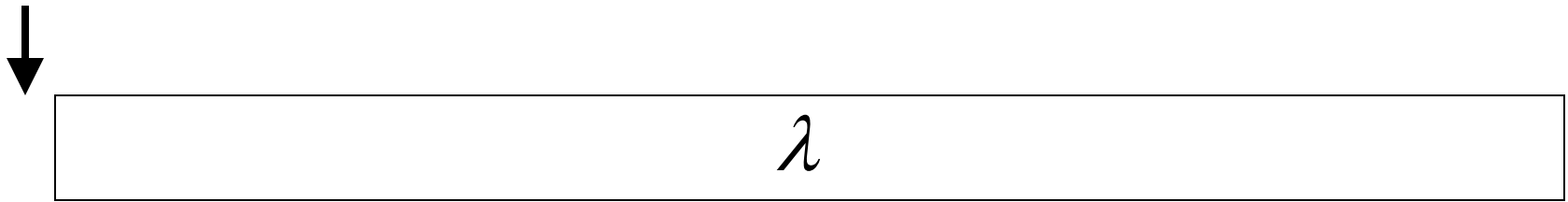

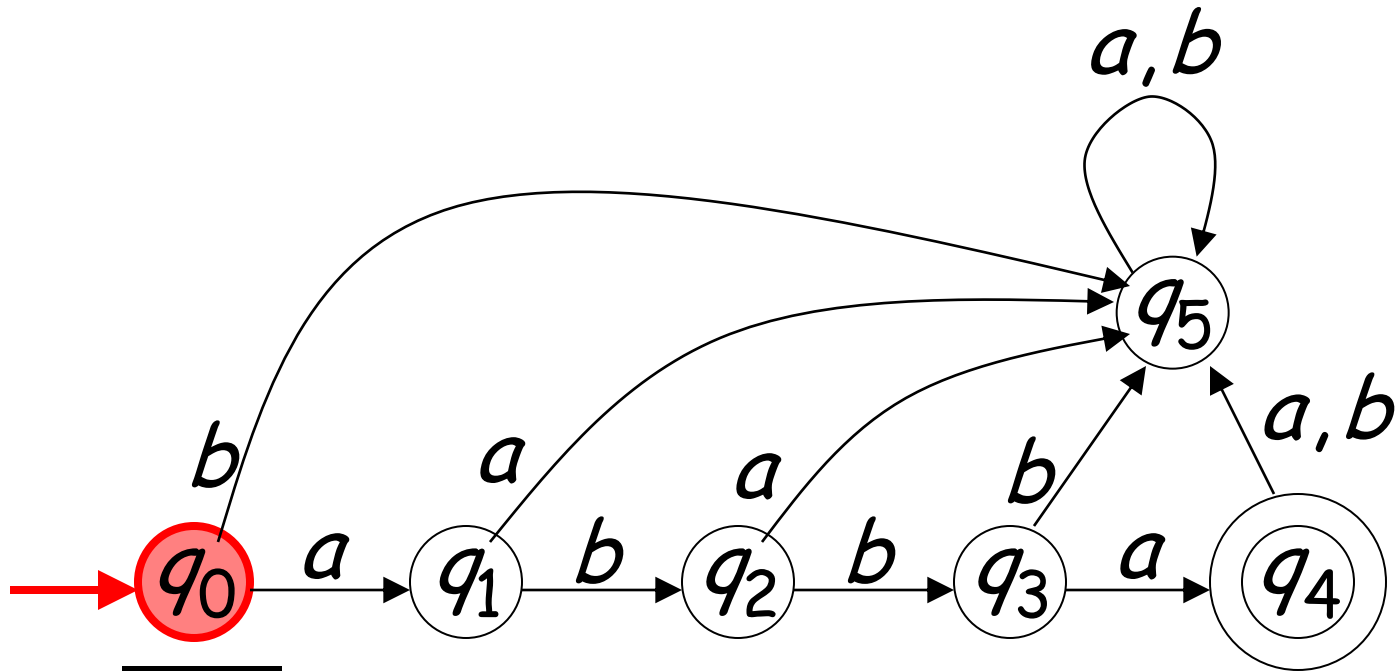
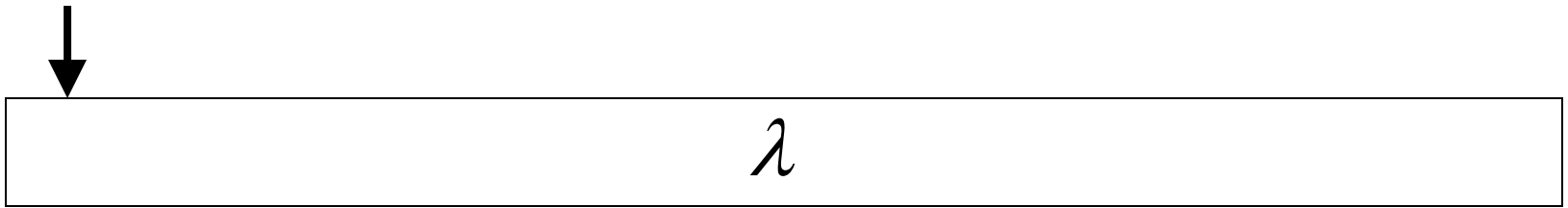

Output:
"reject"

Another Example

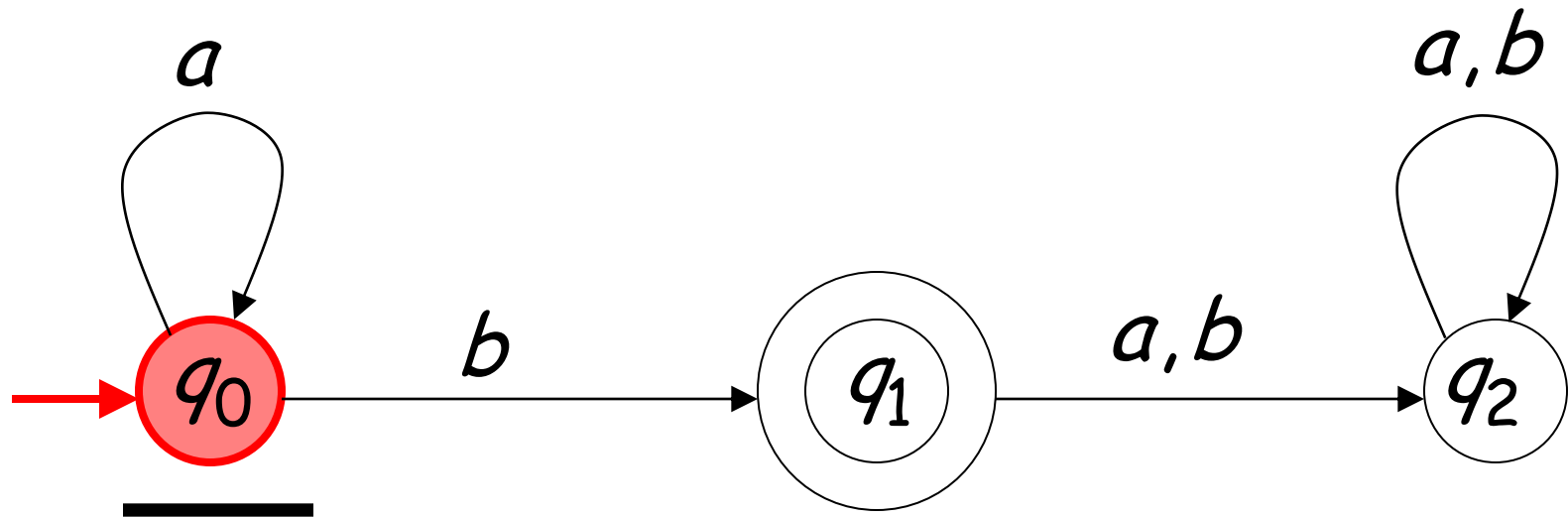
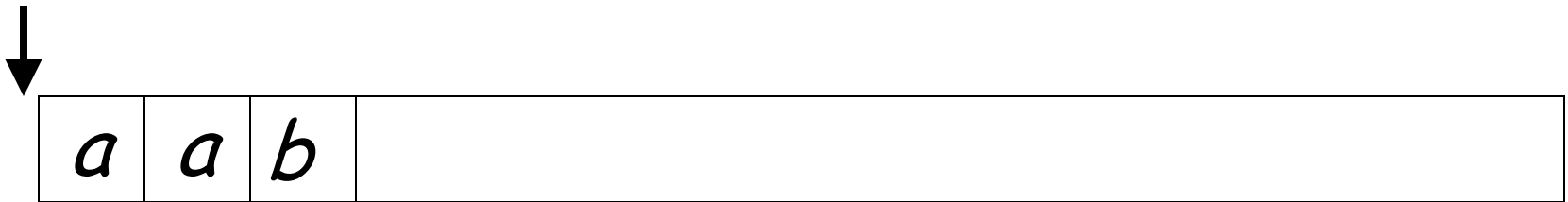

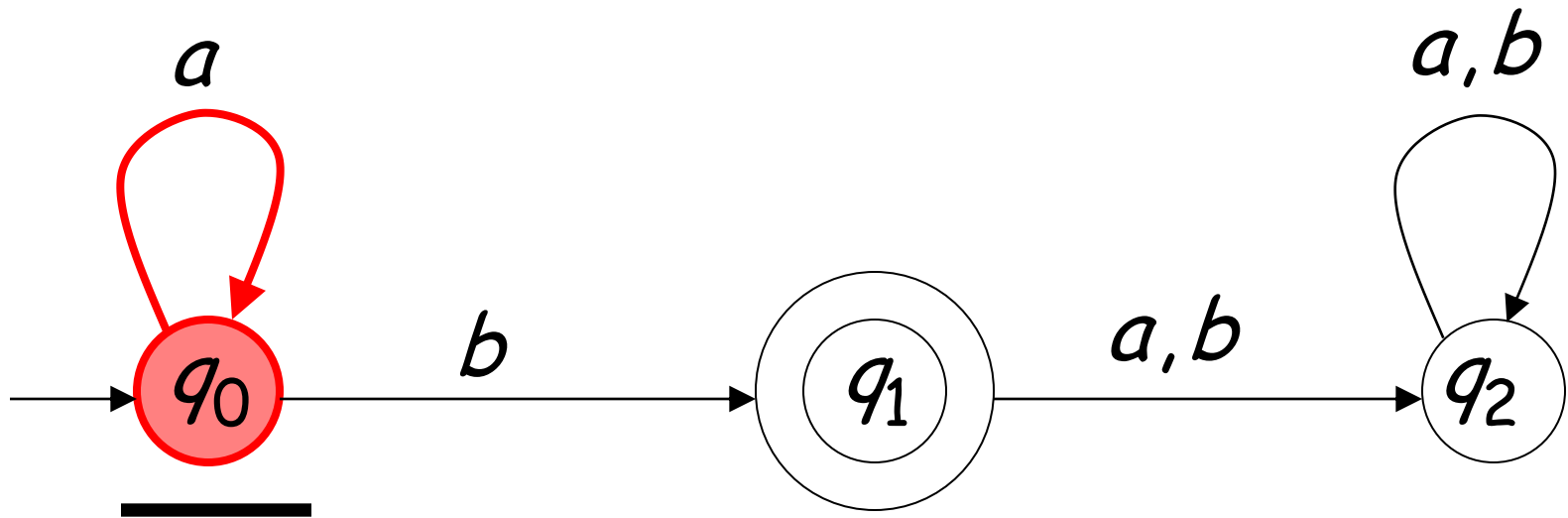
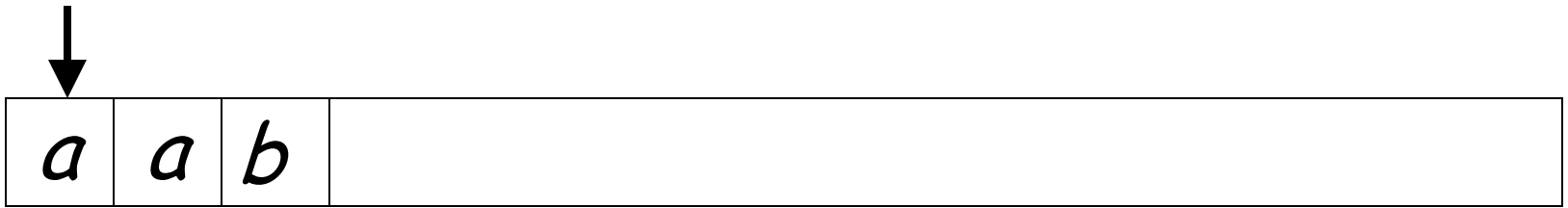

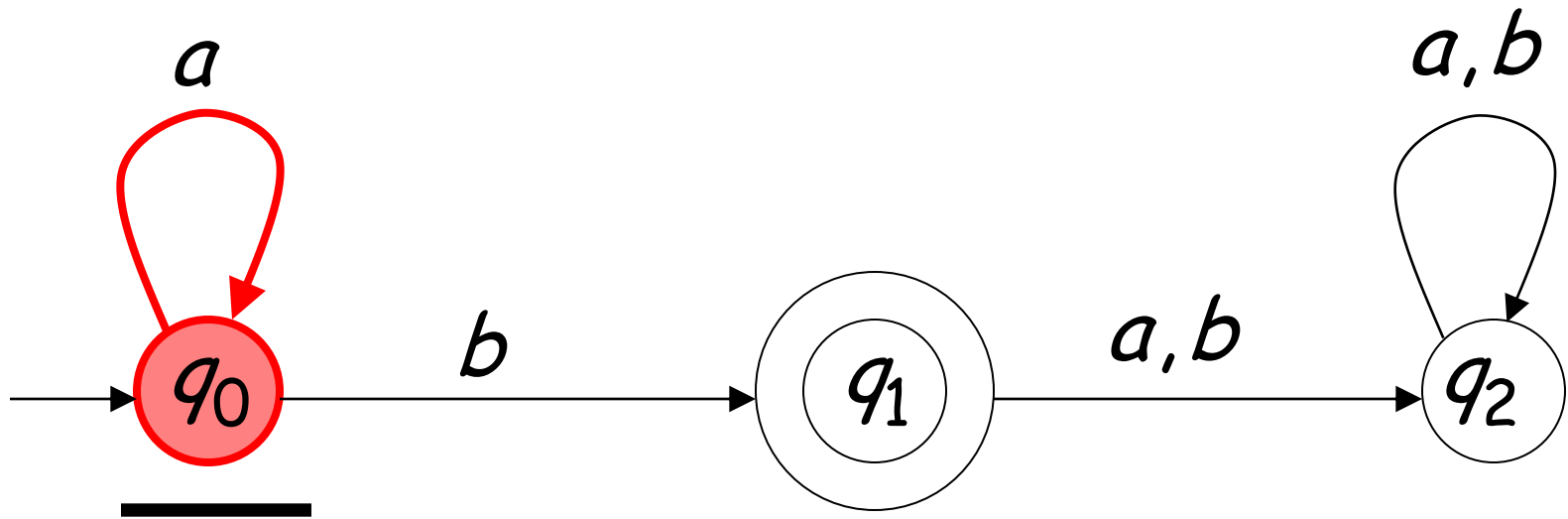
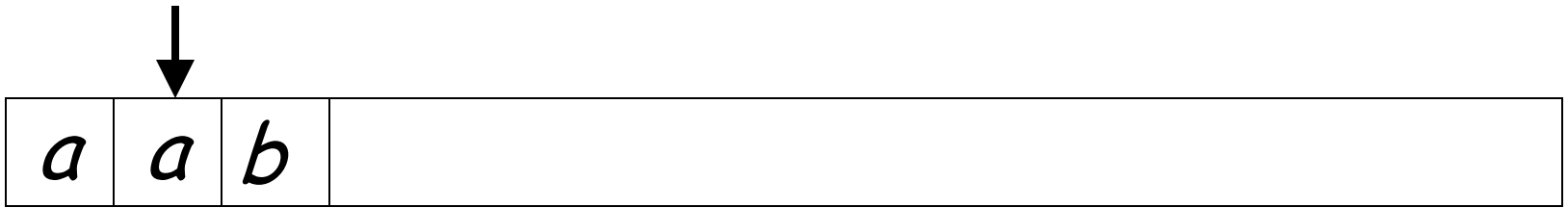

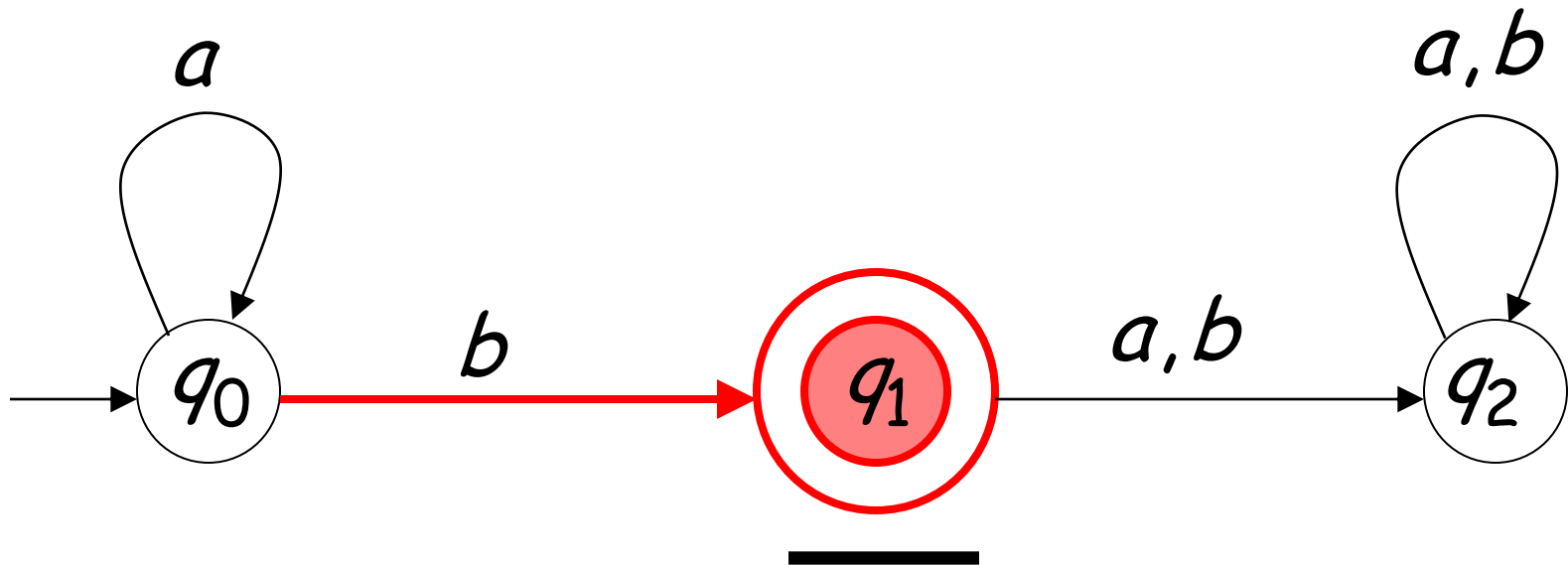
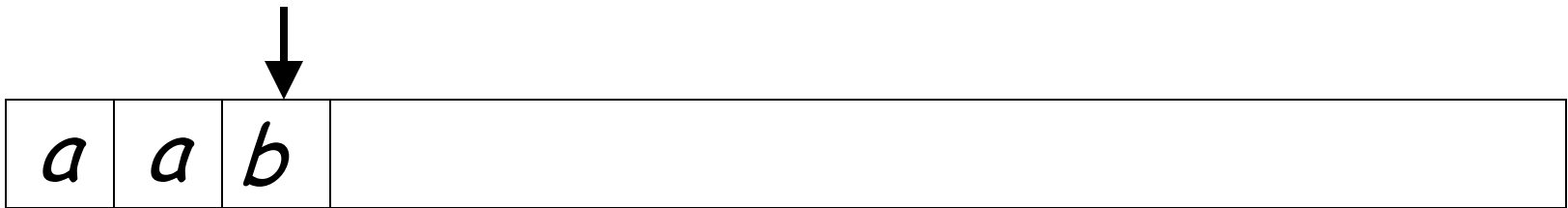

Input finished

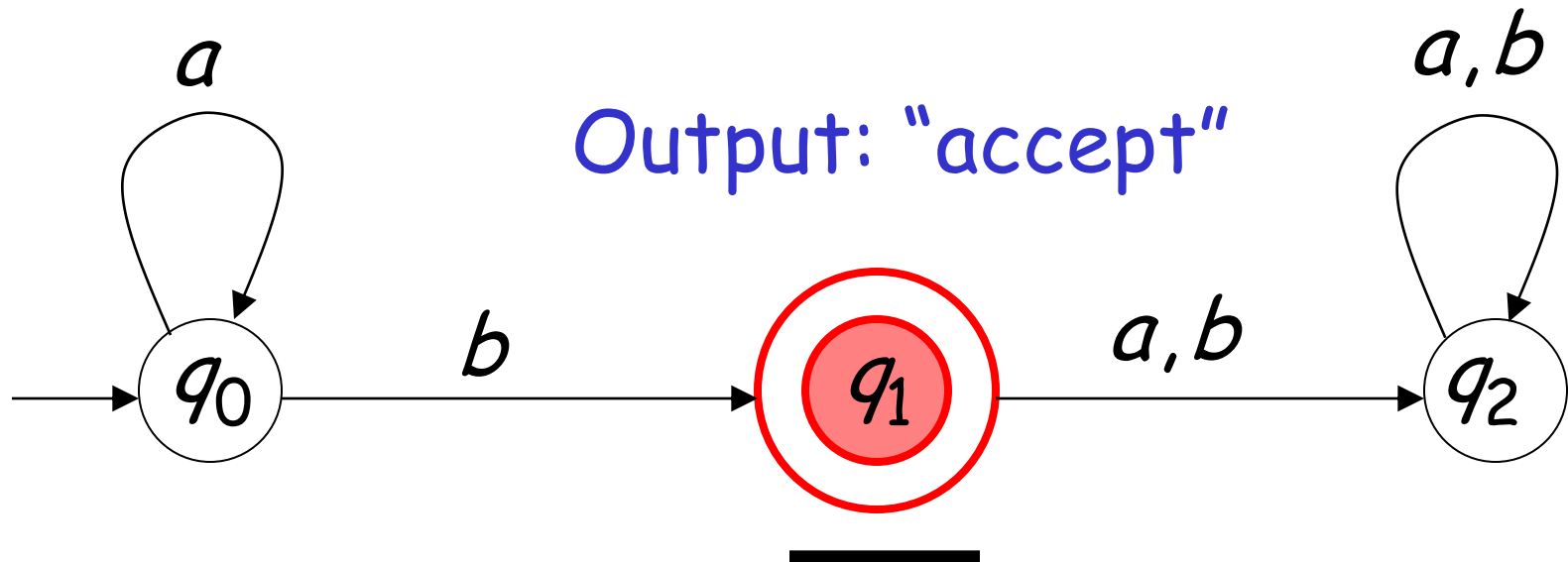

Rejection

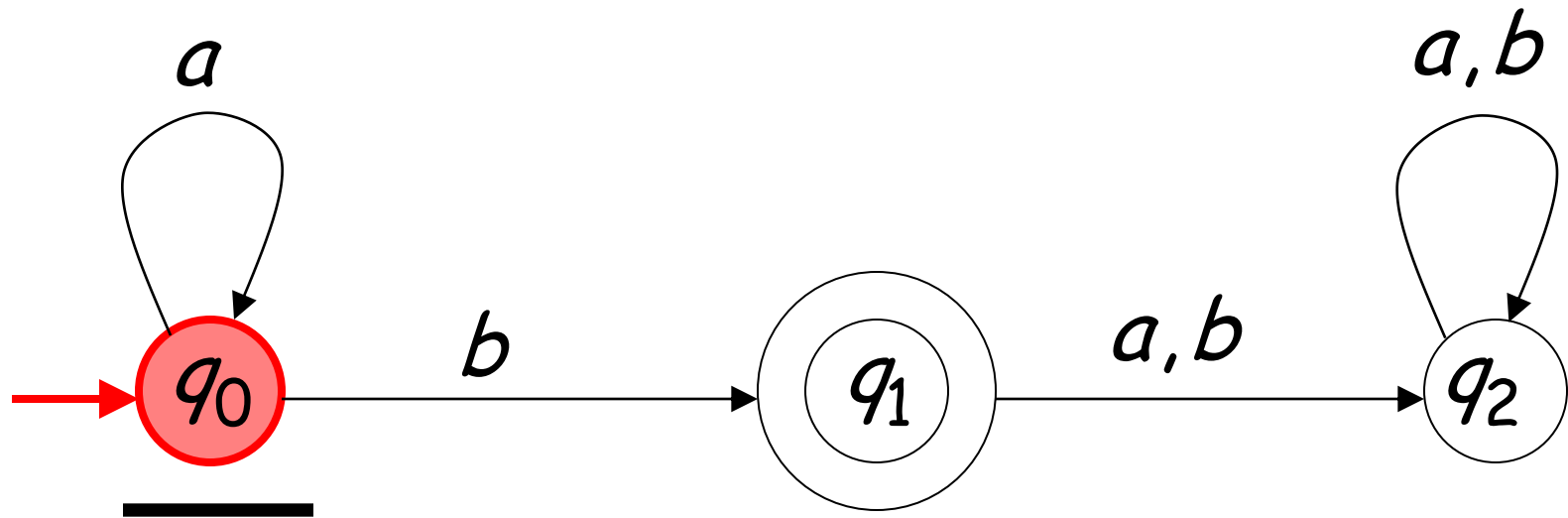
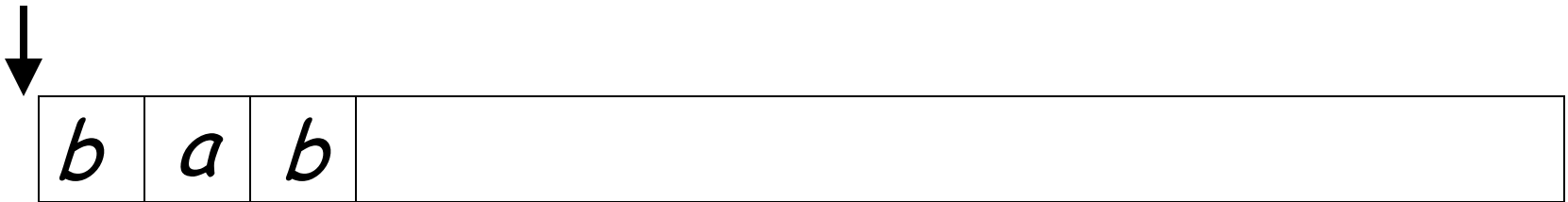

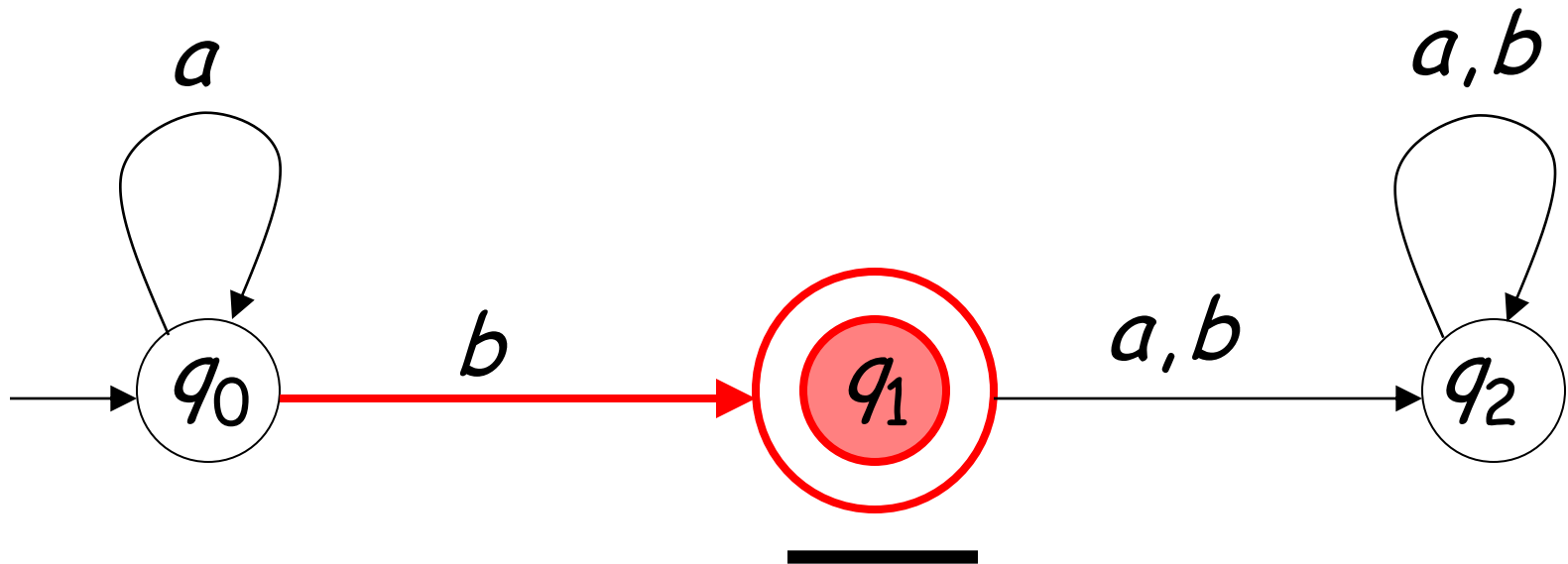
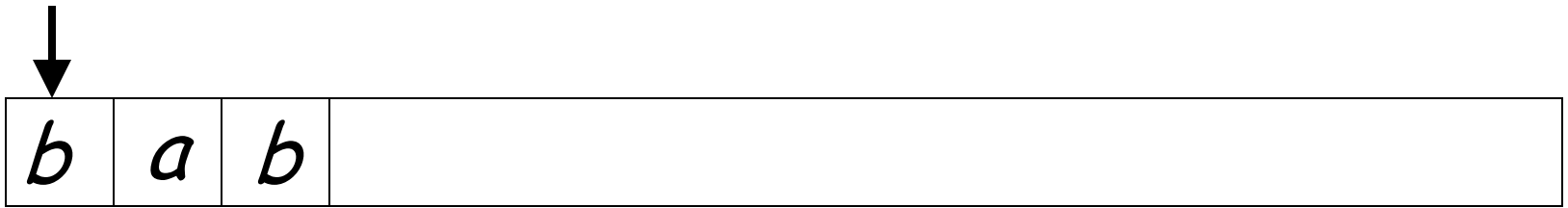

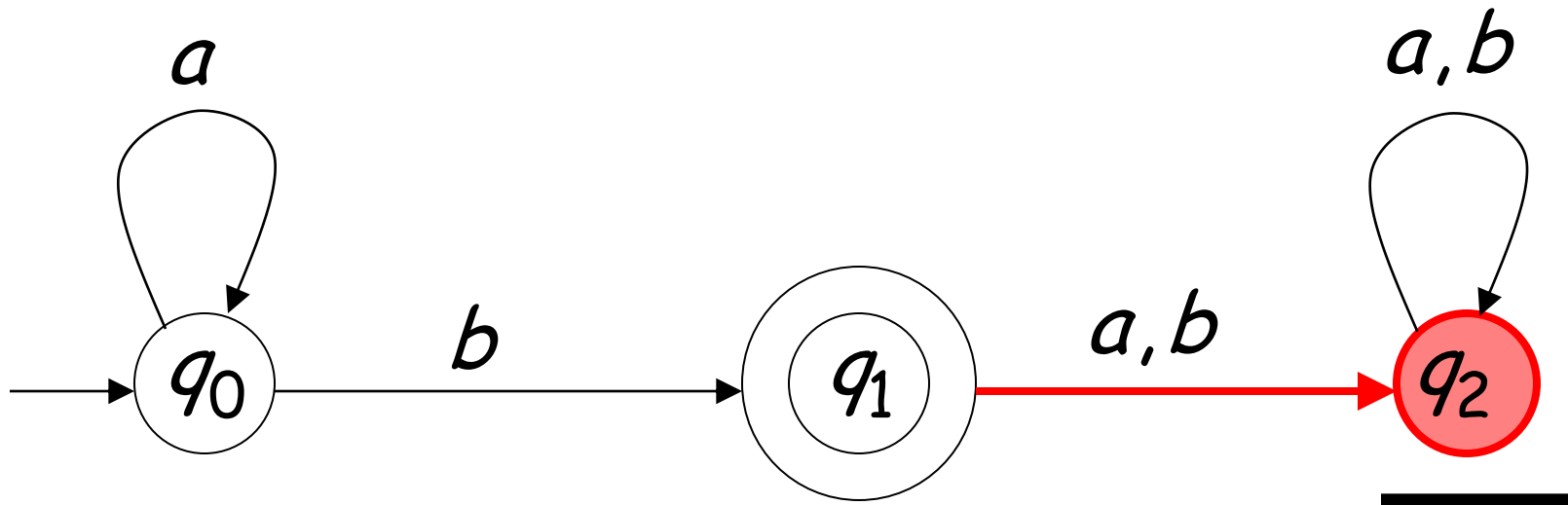
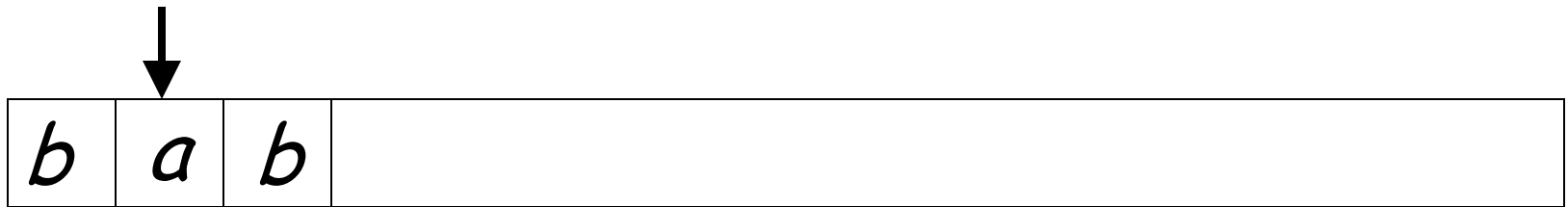

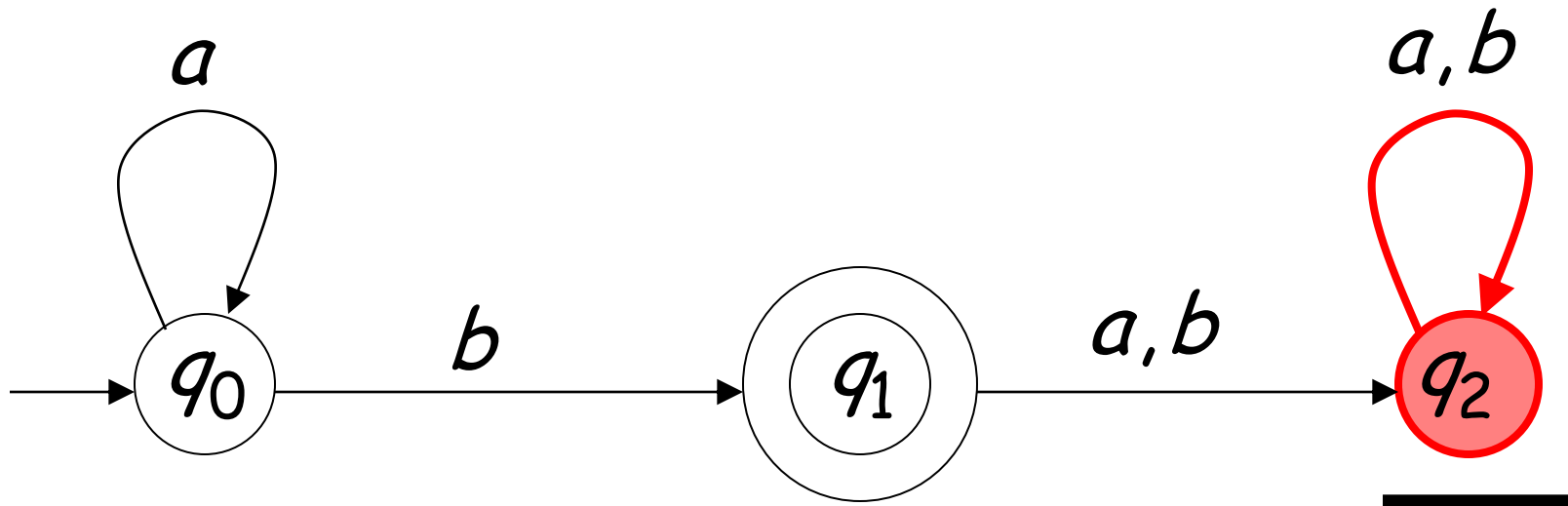
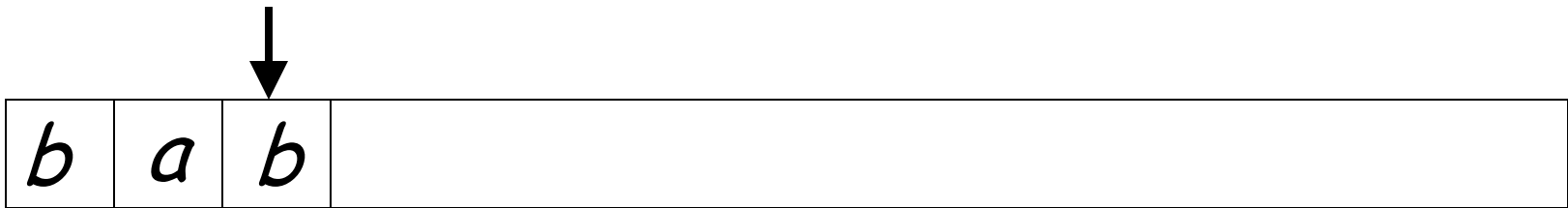

Input finished

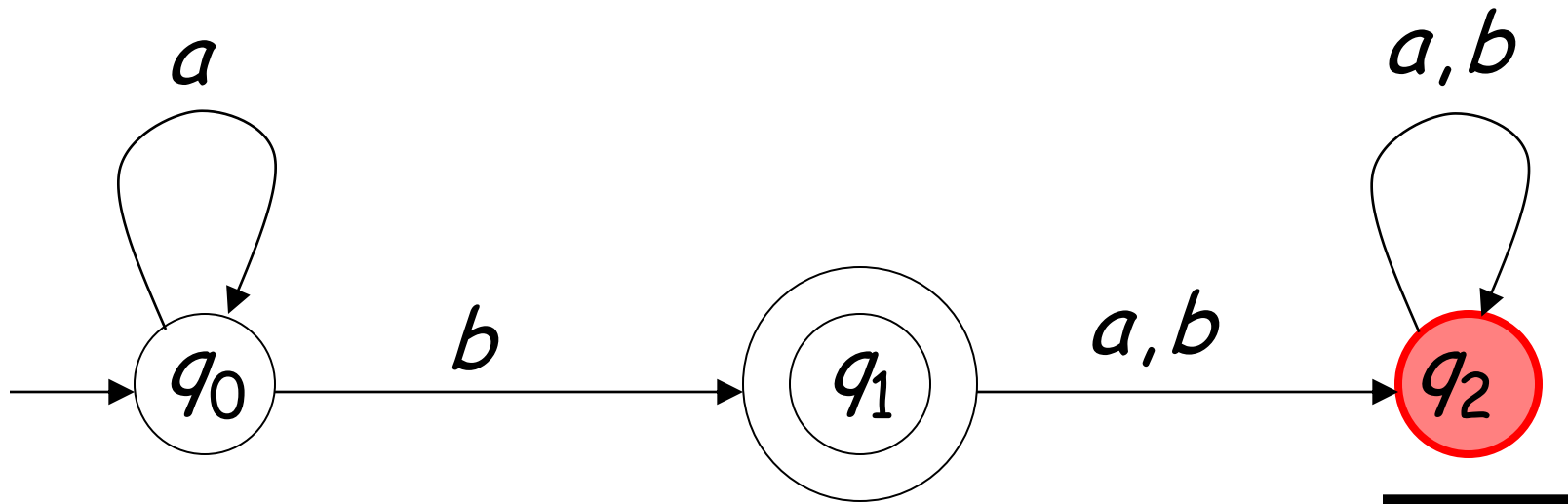
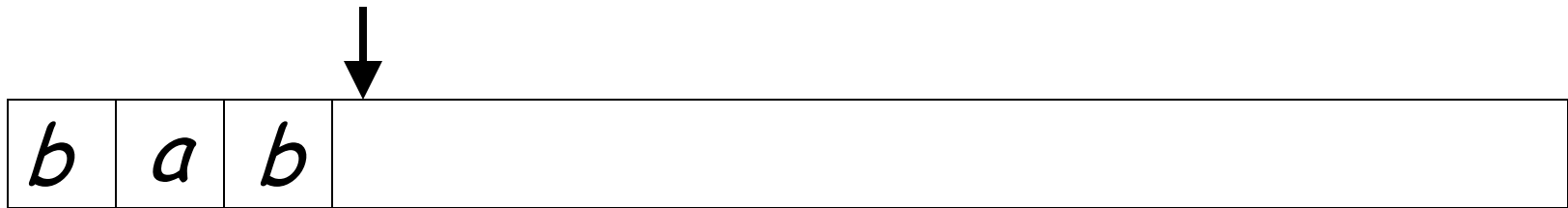

Output: "reject"

Formalities

Deterministic Finite Acceptor (DFA)

$$M = (Q, \Sigma, \delta, q_0, F)$$

Q : set of states

Σ : input alphabet

δ : transition function

q_0 : initial state

F : set of final states

Input Alphabet Σ

$$\Sigma = \{a, b\}$$

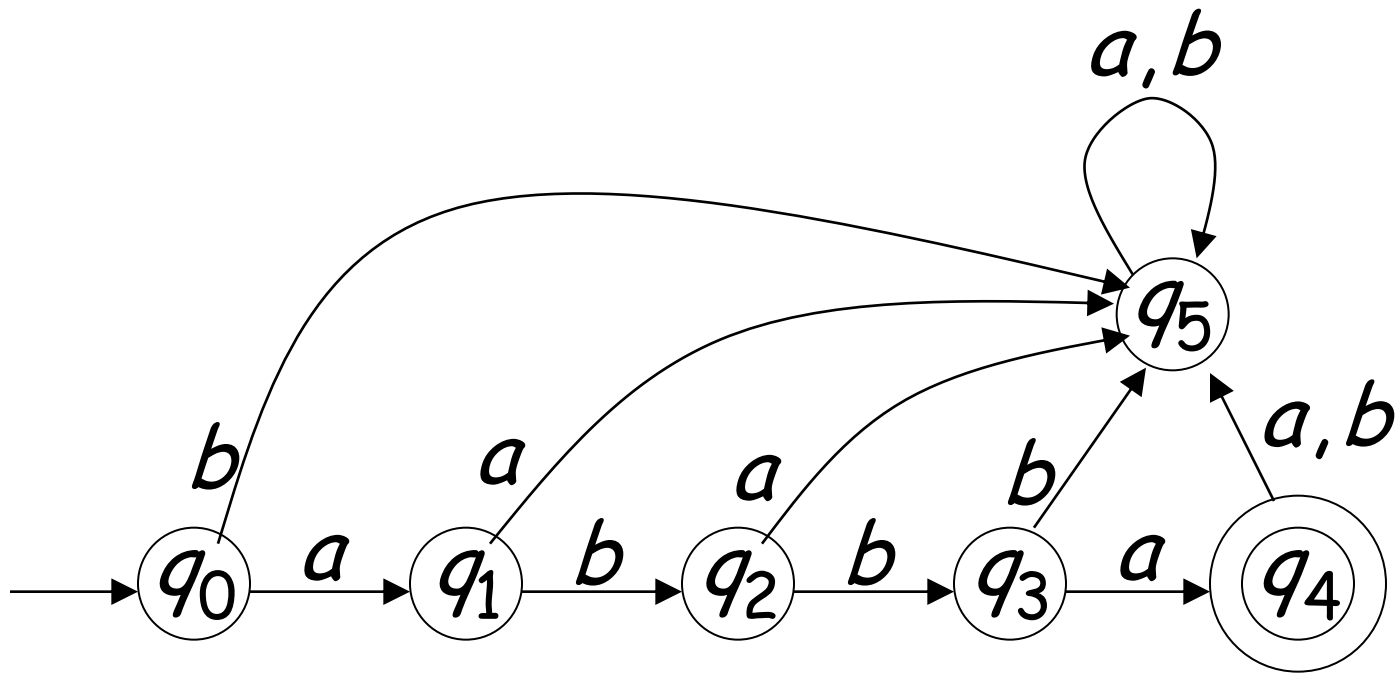

Set of States Q

$$Q = \{q_0, q_1, q_2, q_3, q_4, q_5\}$$

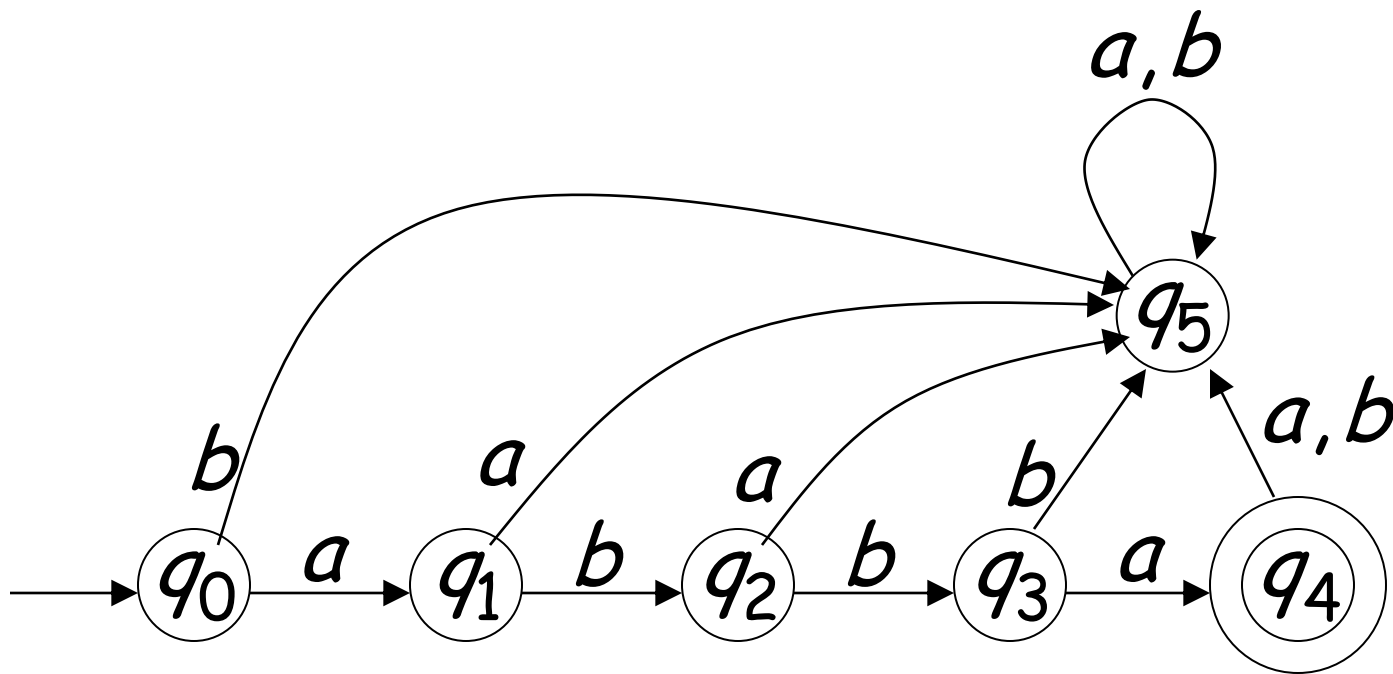

Initial State q_0

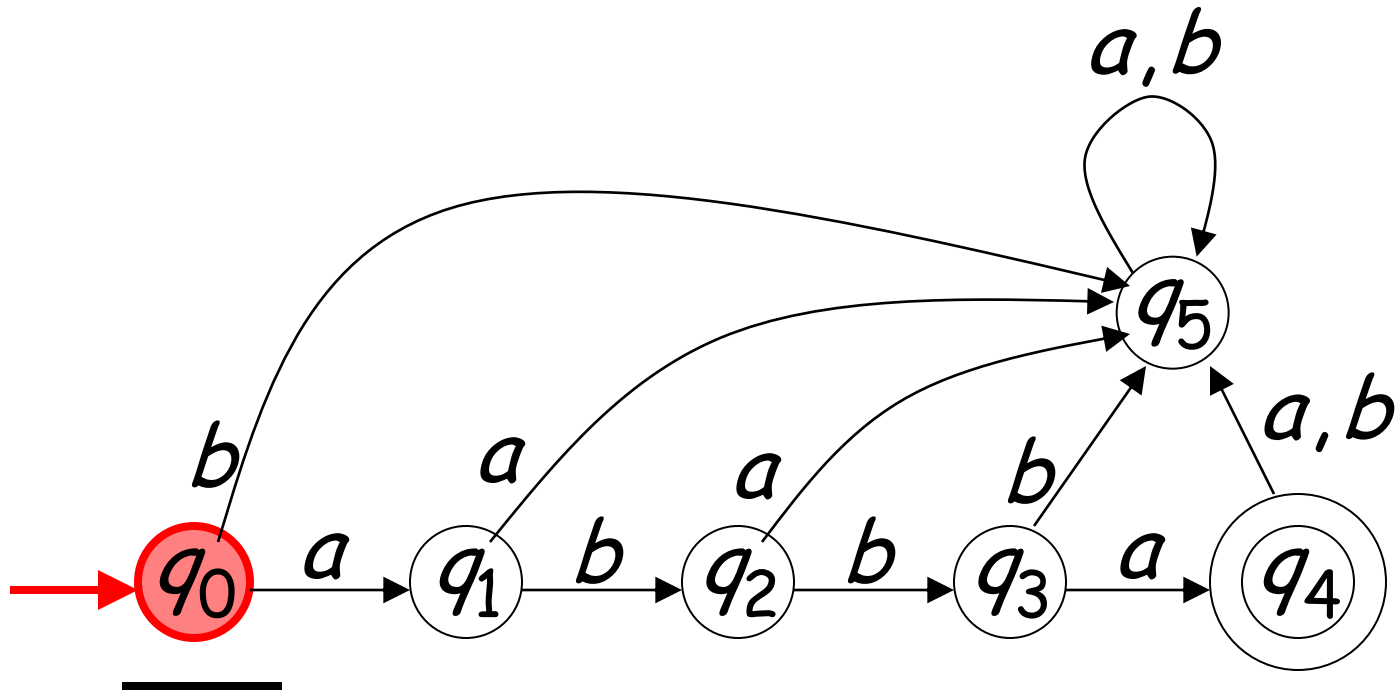

Set of Final States F

$$F = \{q_4\}$$

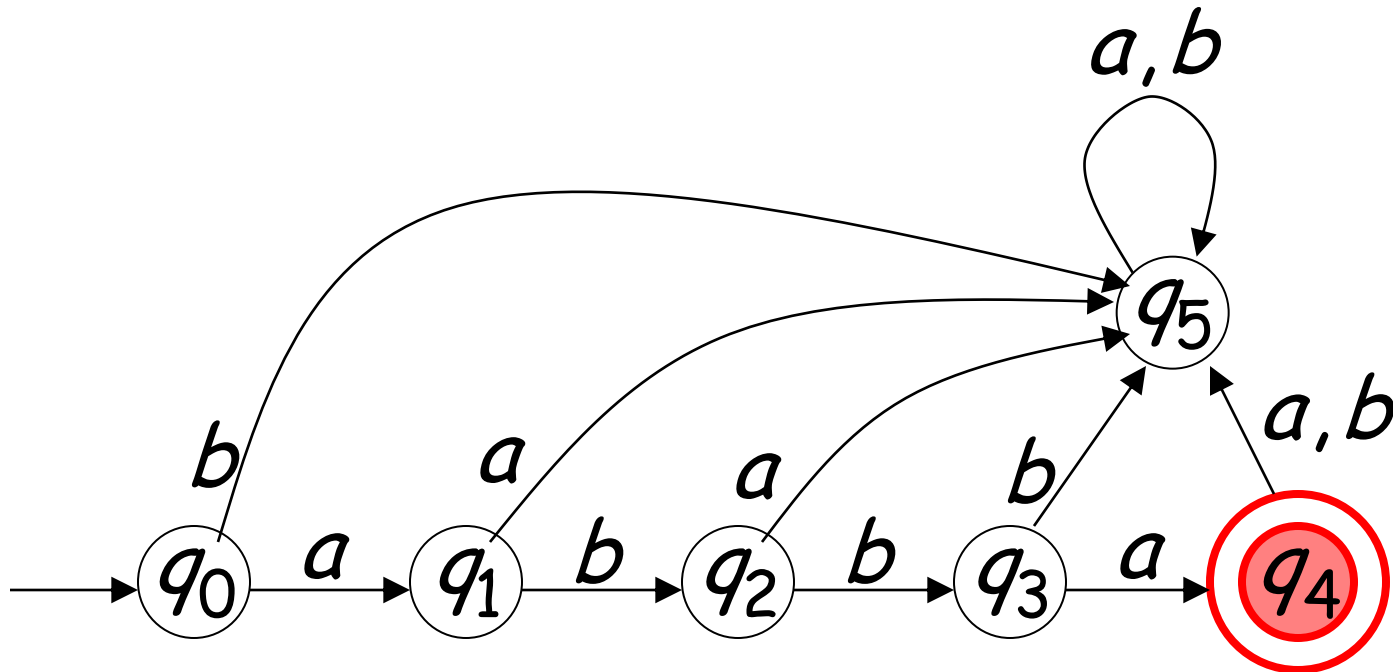

Transition Function δ

$$\delta : Q \times \Sigma \rightarrow Q$$

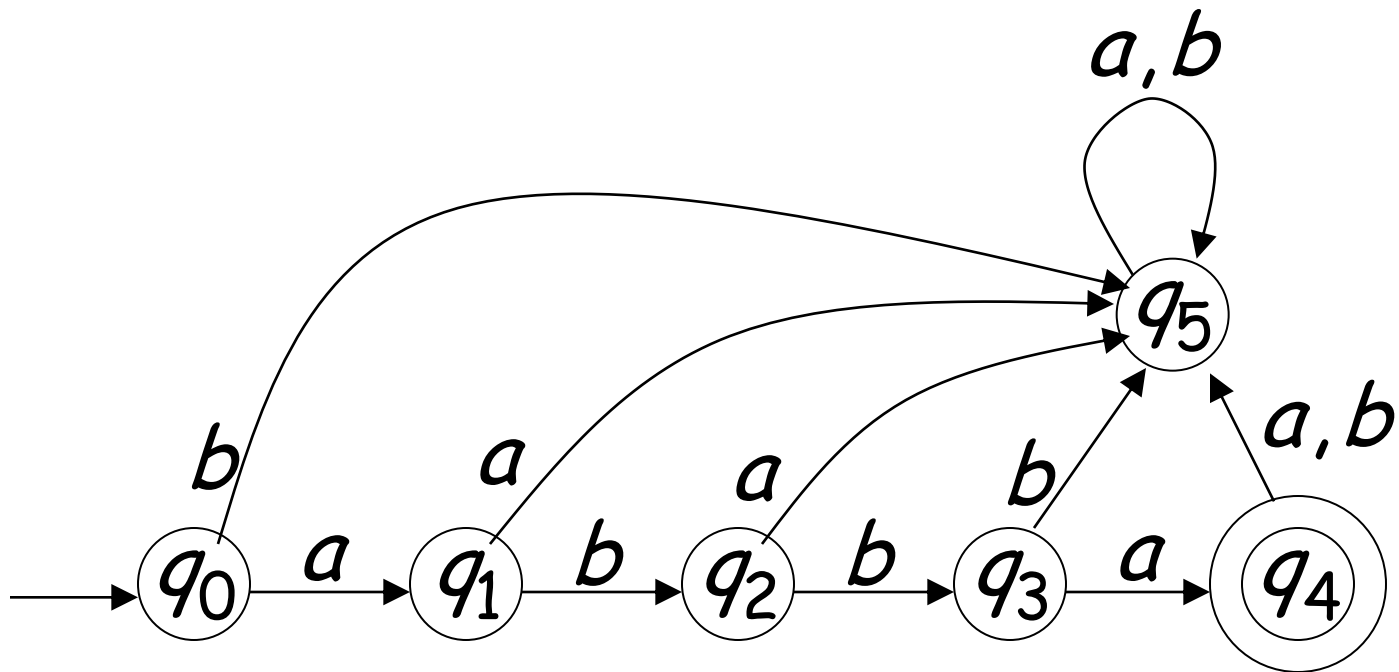

$$\delta(q_0, a) = q_1$$

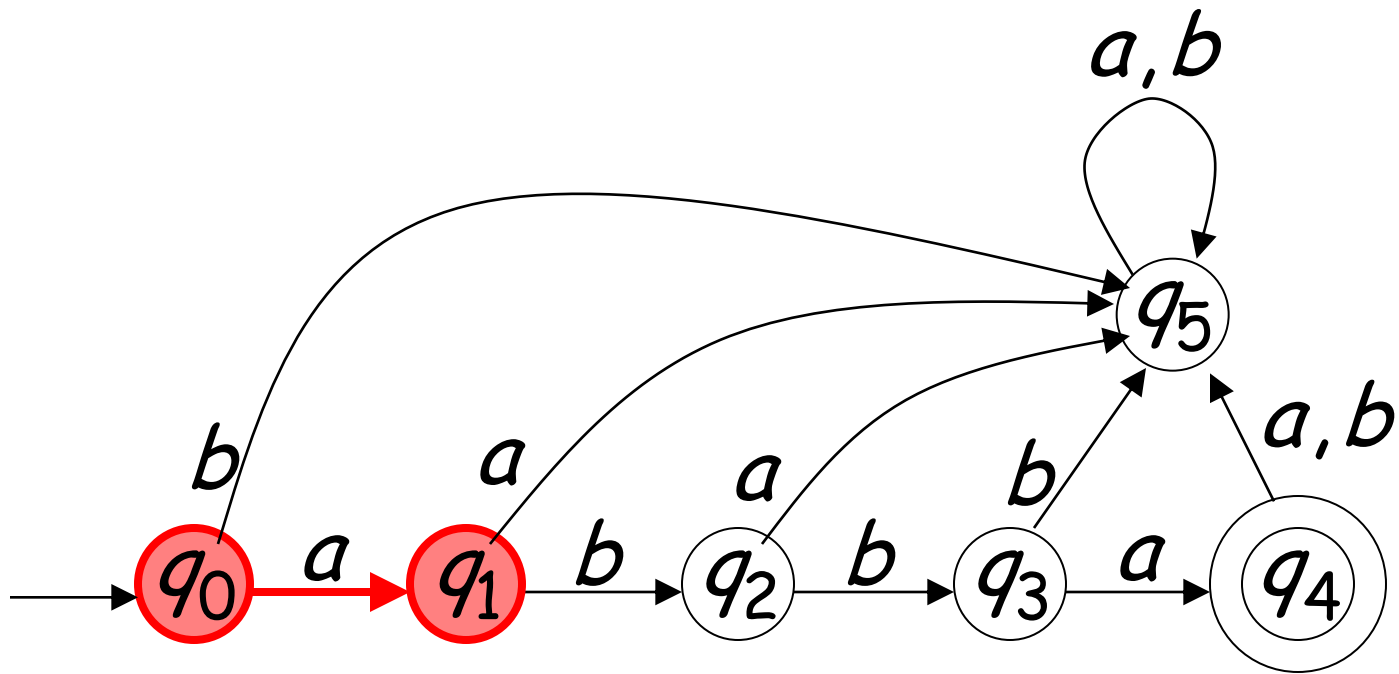

$$\delta(q_0, b) = q_5$$

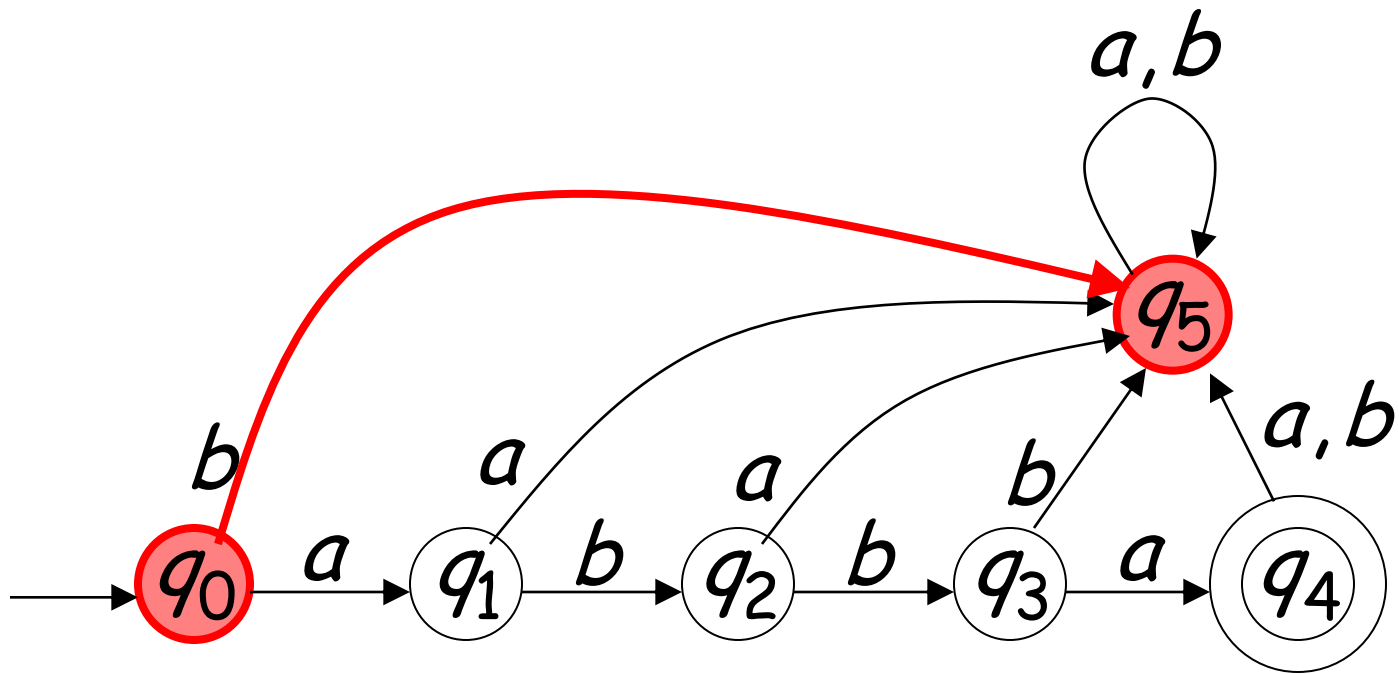

$$\delta(q_2, b) = q_3$$

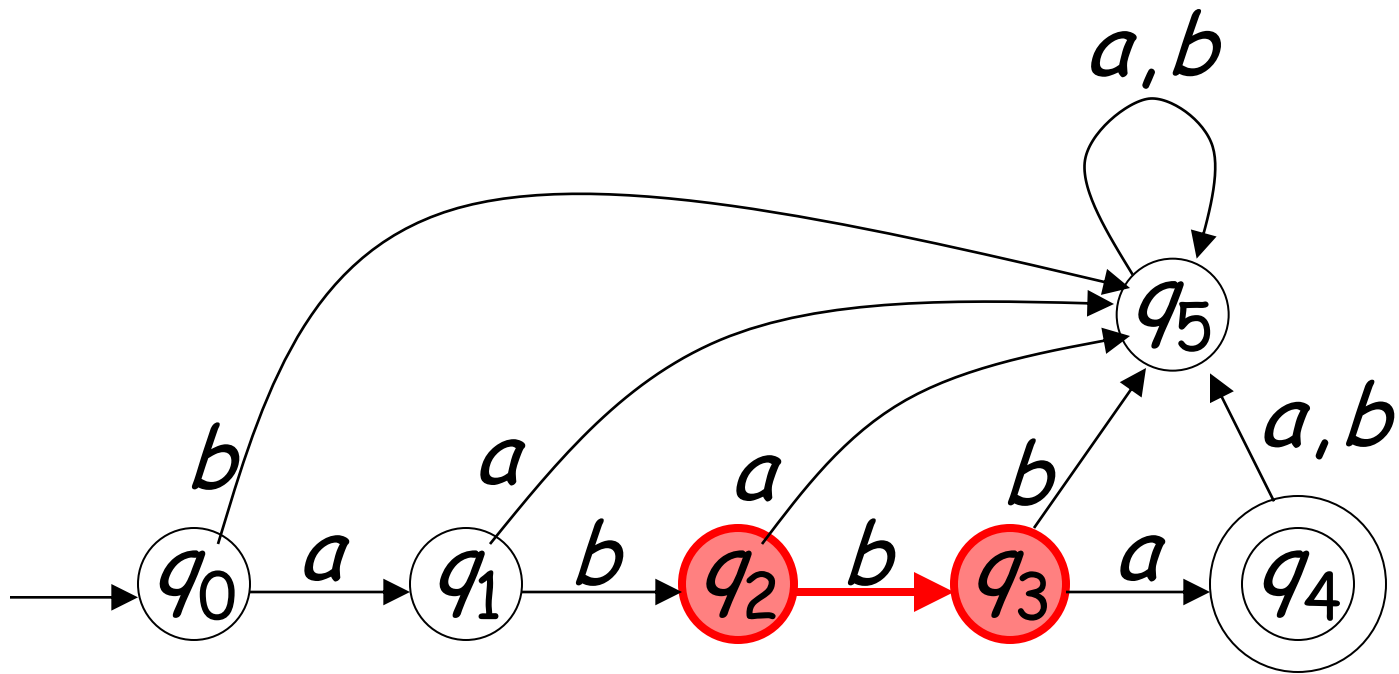

Transition Function δ

δ	a	b
q_0	q_1	q_5
q_1	q_5	q_2
q_2	q_5	q_3
q_3	q_4	q_5
q_4	q_5	q_5
q_5	q_5	q_5

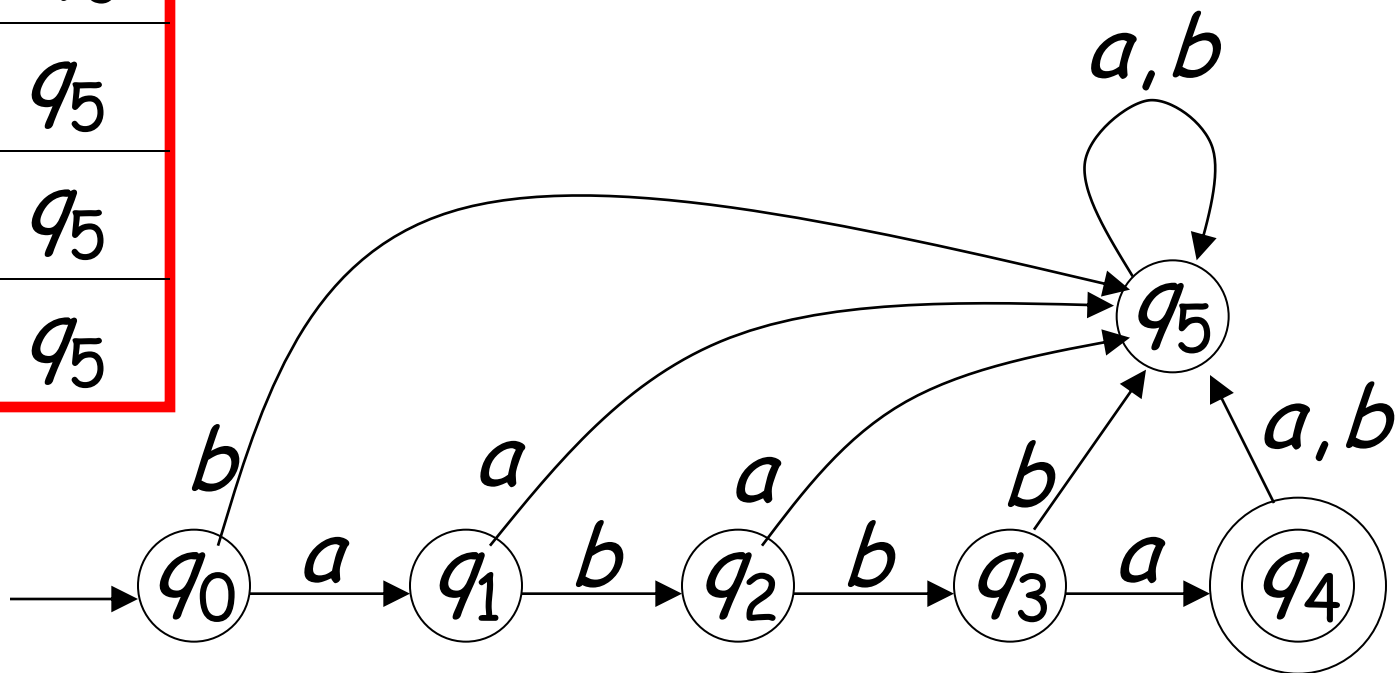

Extended Transition Function δ^*

$$\delta^* : Q \times \Sigma^* \rightarrow Q$$

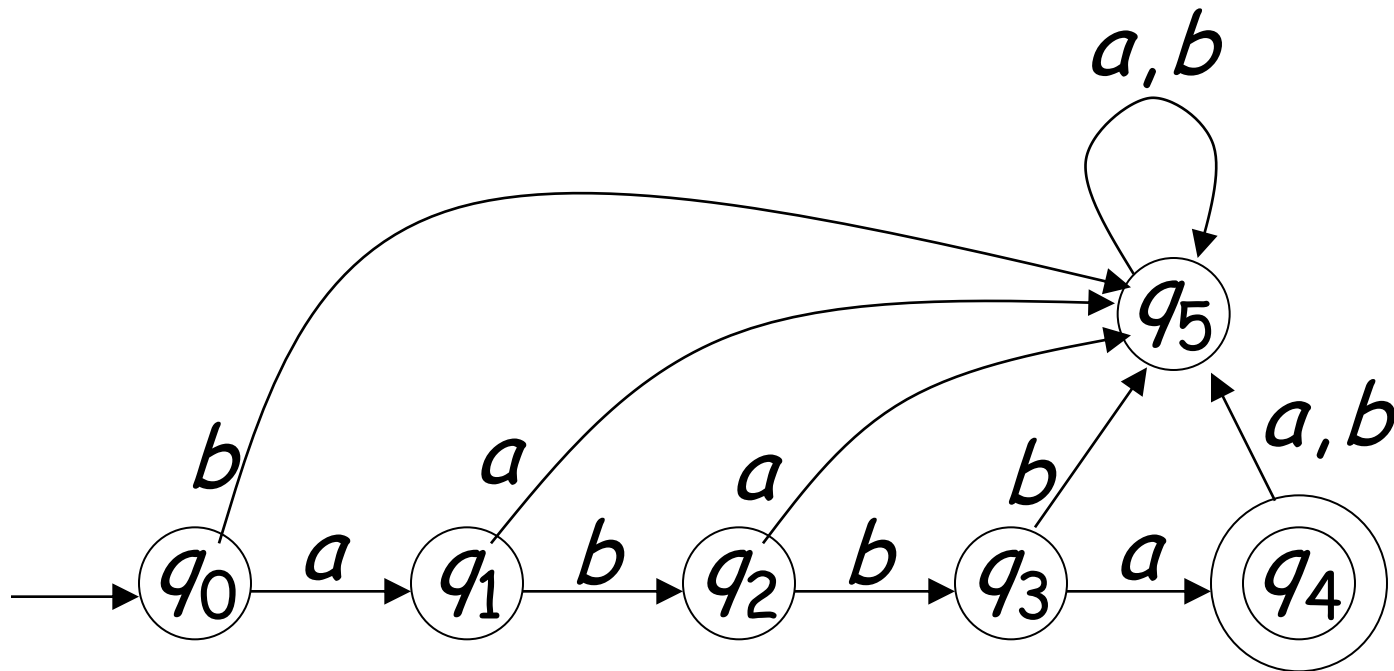

$$\delta^*(q_0, ab) = q_2$$

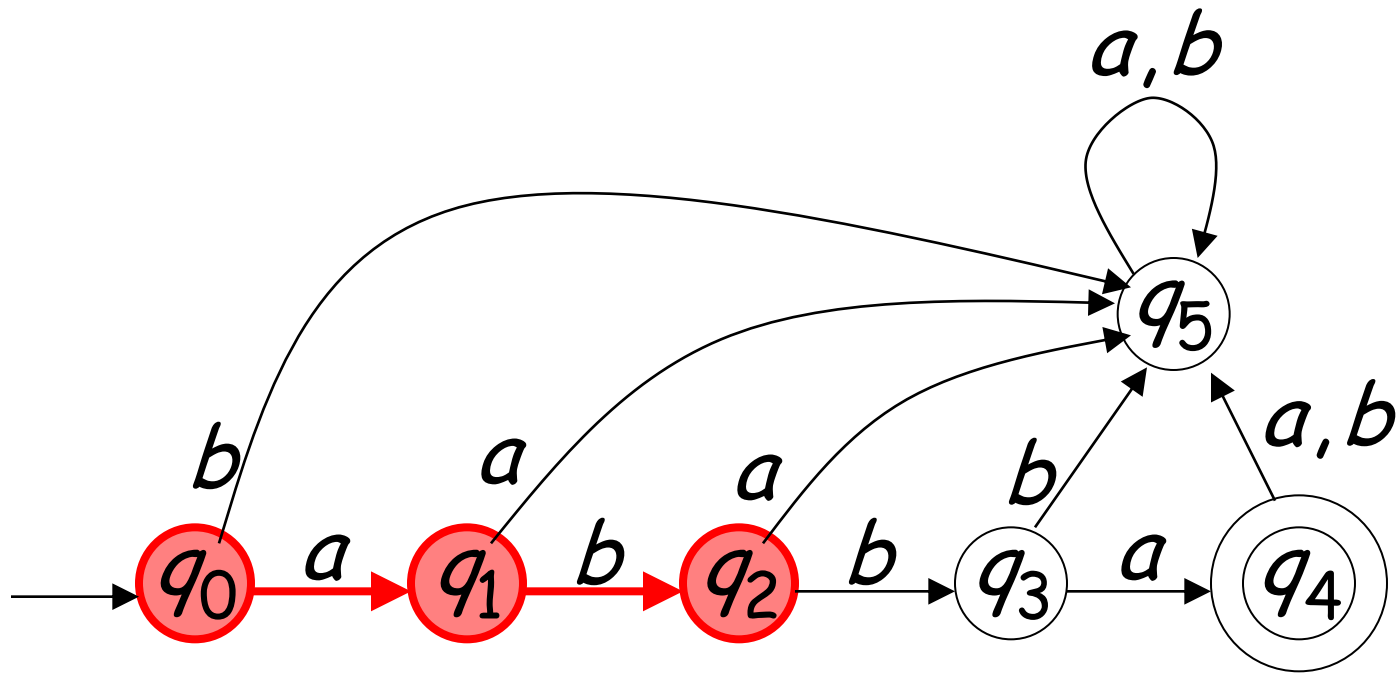

$$\delta^*(q_0, abba) = q_4$$

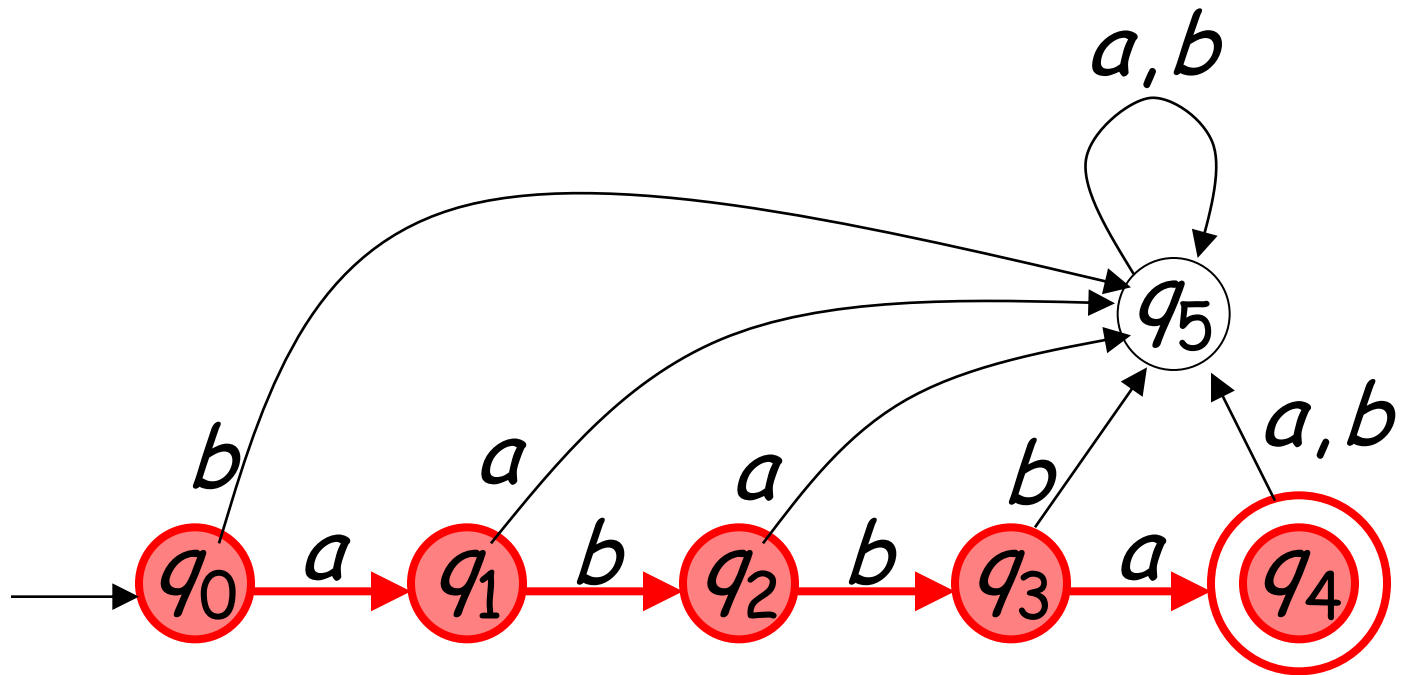

$$\delta^*(q_0, abbbaa) = q_5$$

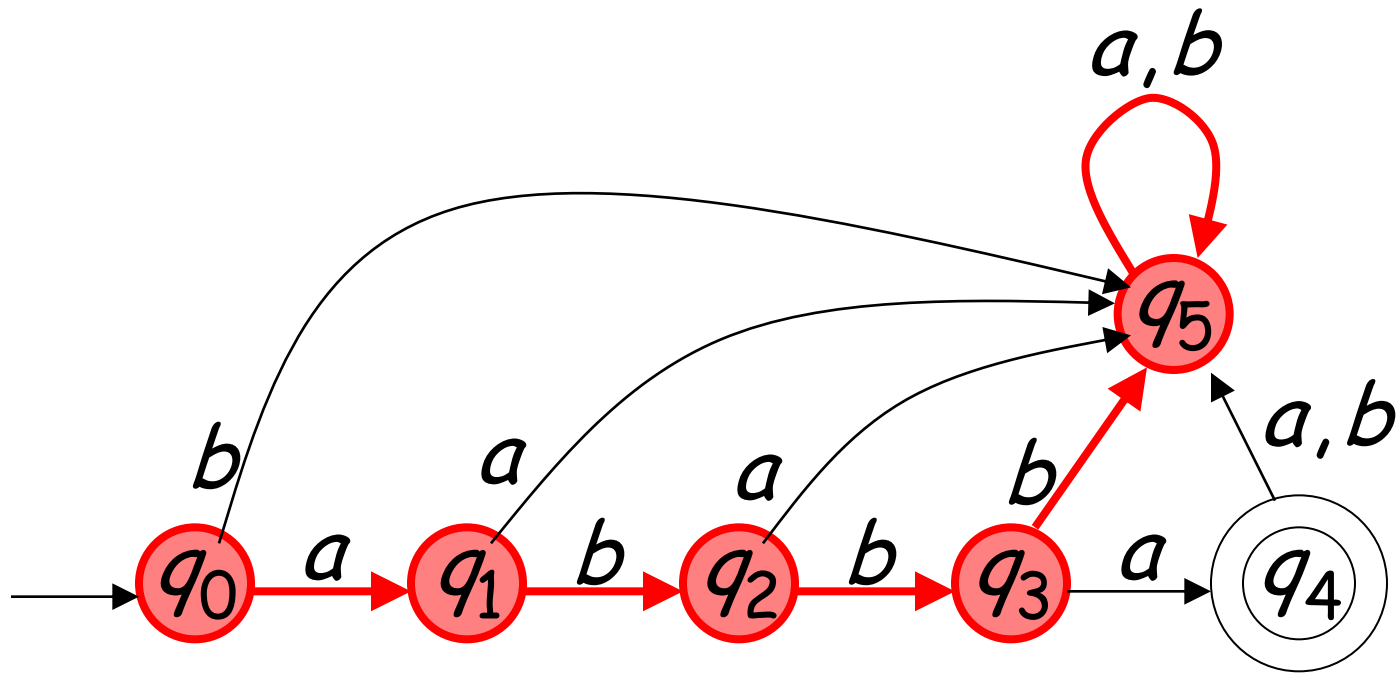

Observation: There is a walk from q to q'
with label w

$$\delta^*(q, w) = q'$$



$$w = \sigma_1 \sigma_2 \cdots \sigma_k$$

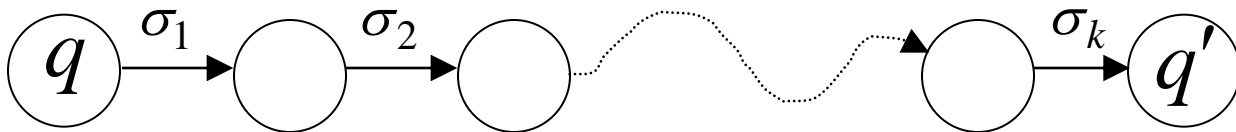

Example: There is a walk from q_0 to q_5
with label $abbbaa$

$$\delta^*(q_0, abbbaa) = q_5$$

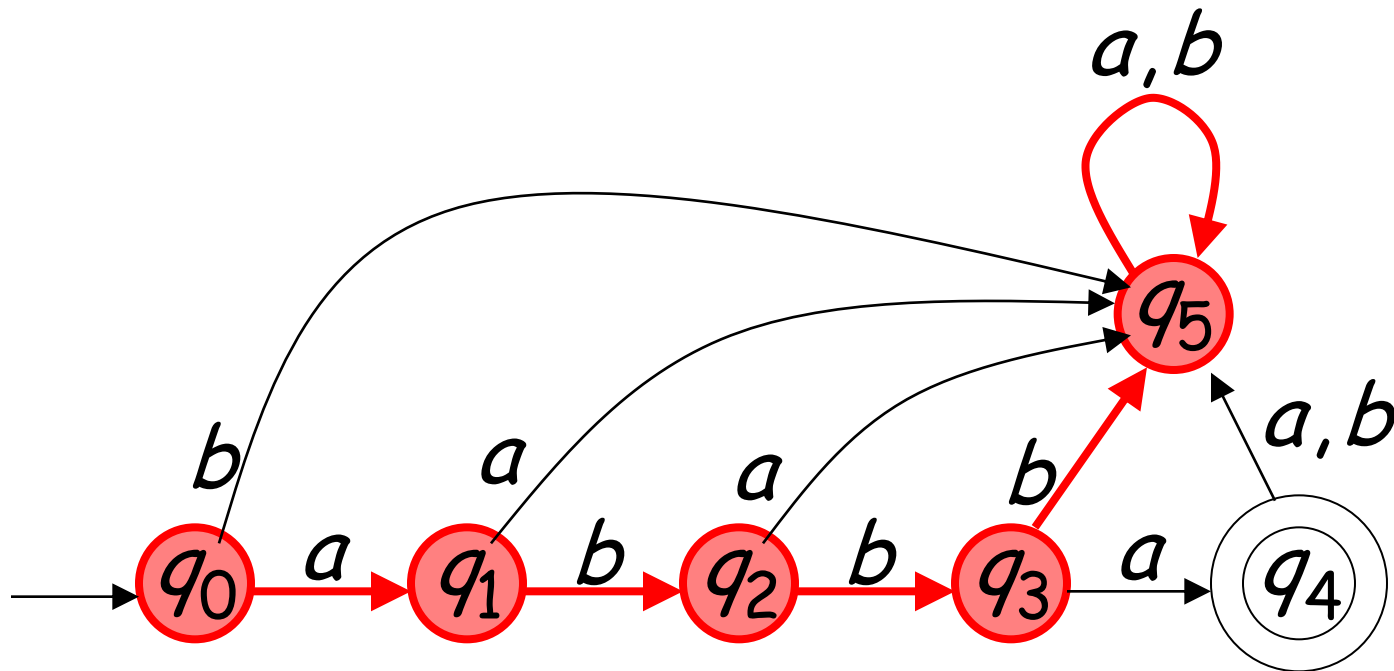

Recursive Definition

$$\delta^*(q, \lambda) = q$$

$$\delta^*(q, w\sigma) = \delta(\delta^*(q, w), \sigma)$$



$$\delta^*(q, w\sigma) = q'$$

$$\delta(q_1, \sigma) = q'$$

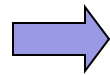

$$\delta^*(q, w\sigma) = \delta(q_1, \sigma)$$

$$\delta^*(q, w) = q_1$$

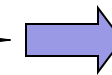

$$\delta^*(q, w\sigma) = \delta(\delta^*(q, w), \sigma)$$

$$\delta^*(q_0, ab) =$$

$$\delta(\delta^*(q_0, a), b) =$$

$$\delta(\delta(\delta^*(q_0, \lambda), a), b) =$$

$$\delta(\delta(q_0, a), b) =$$

$$\delta(q_1, b) =$$

q_2

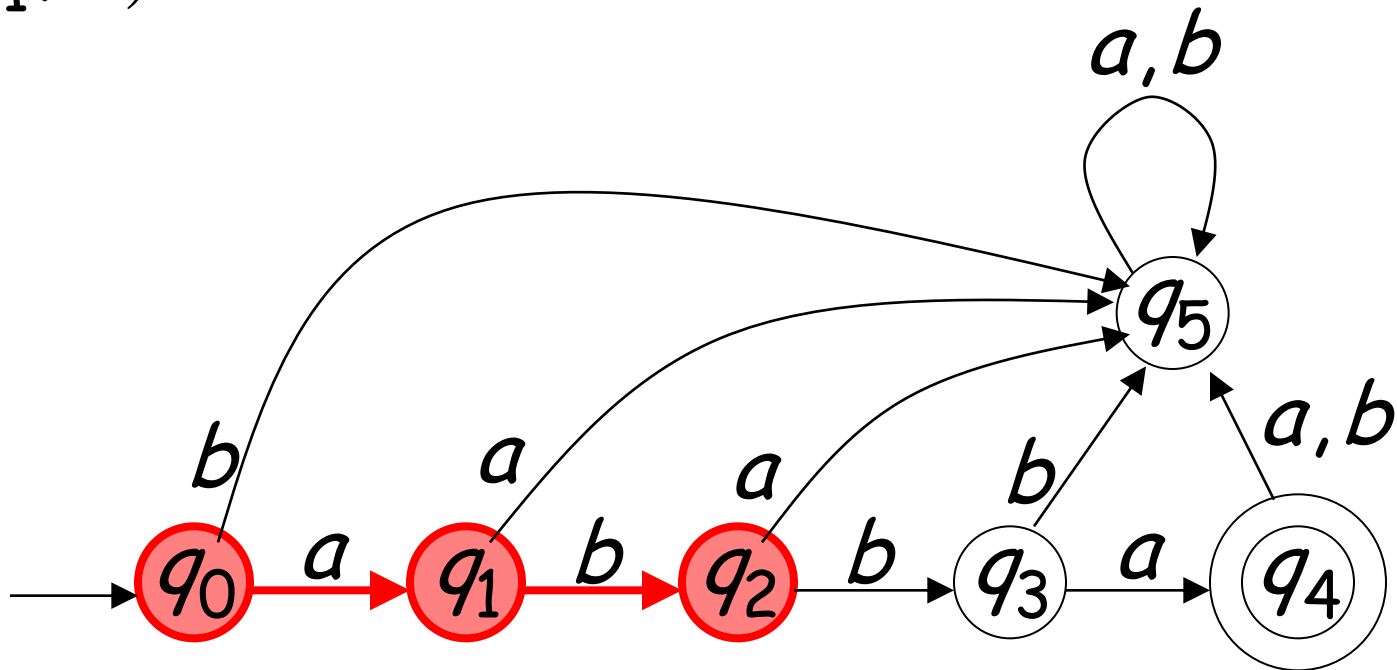

Languages Accepted by DFAs

Take DFA M

Definition:

The language $L(M)$ contains
all input strings accepted by M

$L(M) = \{ \text{strings that drive } M \text{ to a final state} \}$

Example

$$L(M) = \{abba\}$$

M

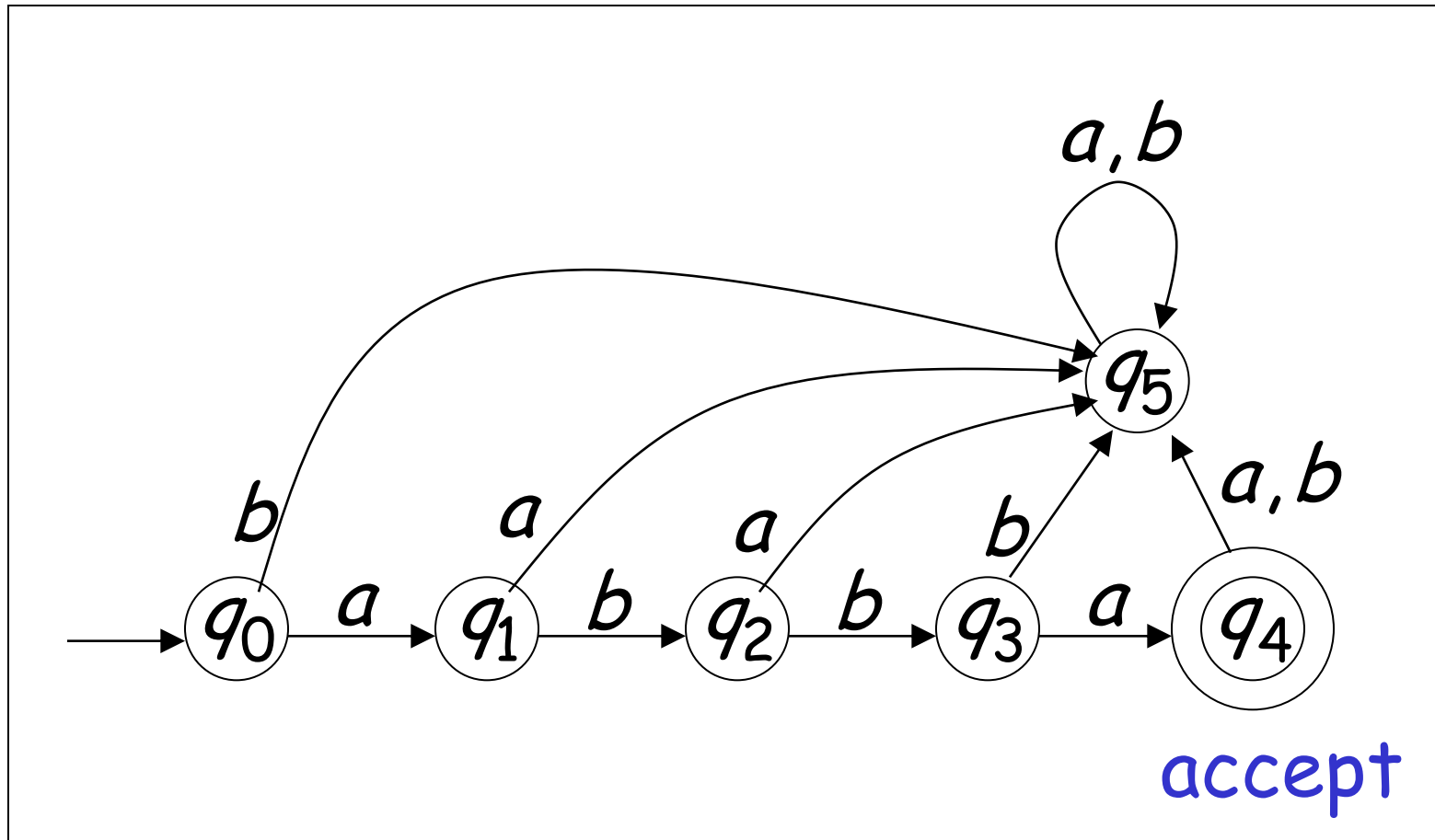

Another Example

$$L(M) = \{\lambda, ab, abba\}$$

M

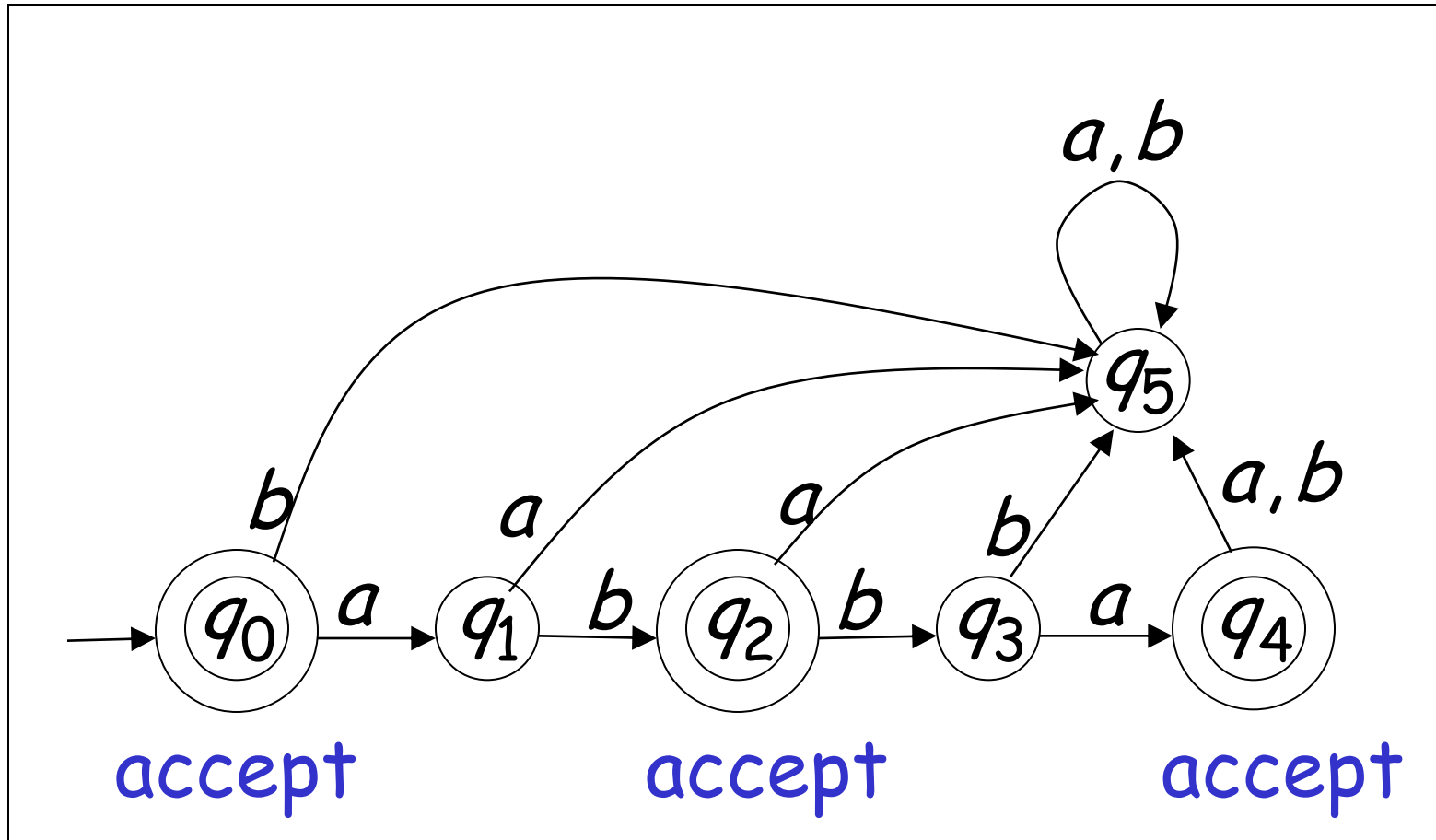

Formally

For a DFA $M = (Q, \Sigma, \delta, q_0, F)$

Language accepted by M :

$$L(M) = \{w \in \Sigma^* : \delta^*(q_0, w) \in F\}$$



Observation

Language rejected by M :

$$\overline{L(M)} = \{w \in \Sigma^* : \delta^*(q_0, w) \notin F\}$$



More Examples

$$L(M) = \{a^n b : n \geq 0\}$$

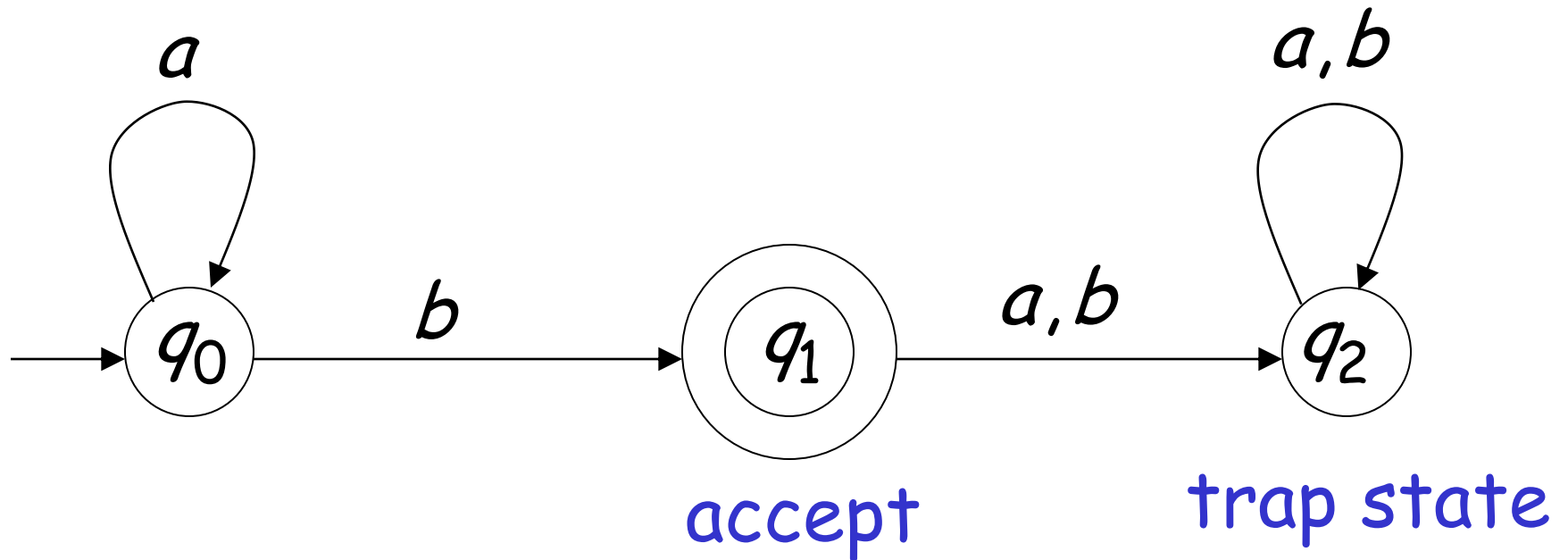

$L(M) = \{ \text{all strings without} \\ \text{substring } 001 \}$

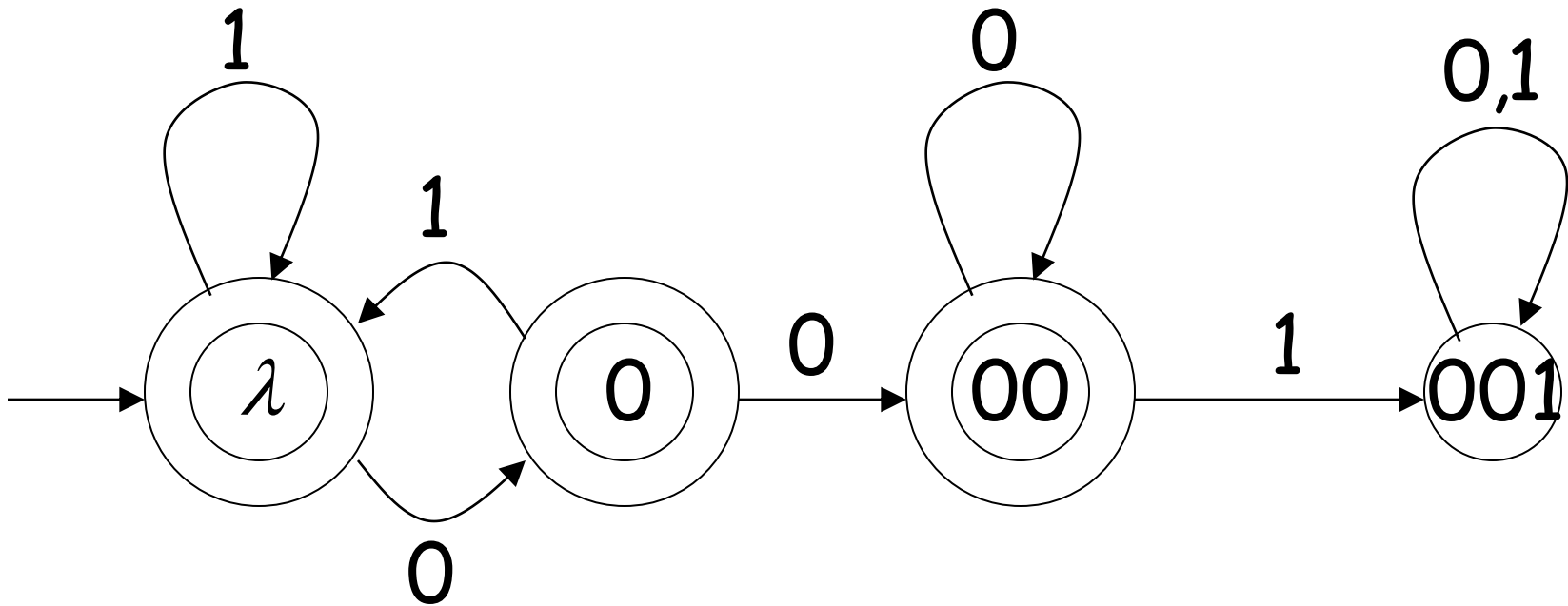

Regular Languages

A language L is regular if there is a DFA M such that $L = L(M)$

All regular languages form a language family

Examples of regular languages:

$\{abba\}$ $\{\lambda, ab, abba\}$ $\{a^n b : n \geq 0\}$

$\{ \text{all strings with prefix } ab \}$

$\{ \text{all strings without substring } 001 \}$

There exist automata that accept these Languages (see previous slides).

Another Example

The language $L = \{awa : w \in \{a,b\}^*\}$
is regular:

$$L = L(M)$$

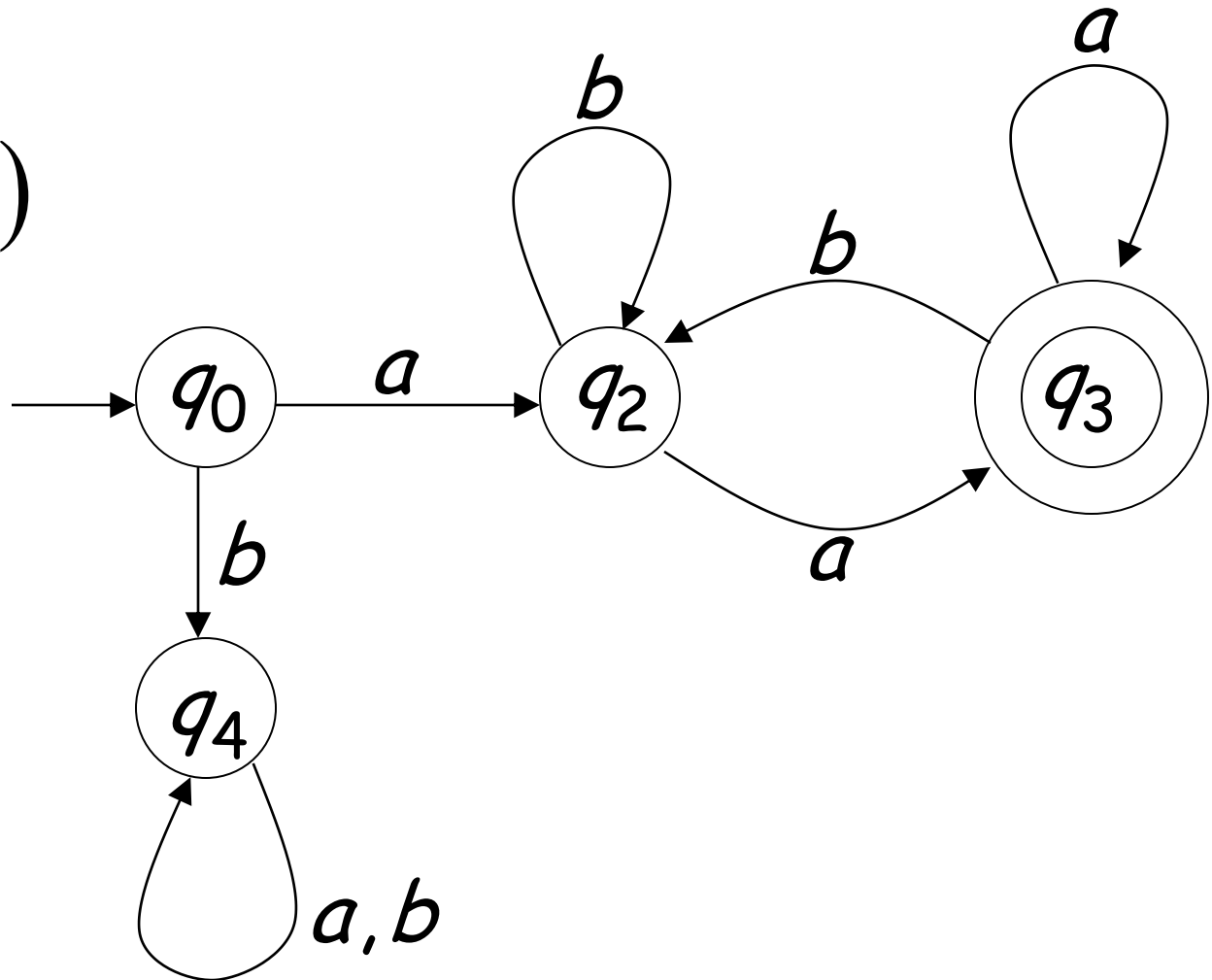

There exist languages which are not Regular:

Example: $L = \{a^n b^n : n \geq 0\}$

There is no DFA that accepts such a language

(we will prove this later in the class)

The End